

Kingdom of Saudi Arabia  
Ministry of Health



National eHealth Strategy and Change Management Office  
(SCMO)

Enabling Standards-Based eHealth Interoperability

IS0011

Saudi eHealth Core Interoperability Specification for eReferral and eTransfer  
Workflow

Version 1.0

February 22, 2015

Document Control Number: IS0011 Saudi eHealth Core IS for Referral Workflow

THIS PAGE INTENTIONALLY LEFT BLANK

# TABLE OF CONTENTS

<b>PREFACE</b> .....	<b>1</b>
DOCUMENT PURPOSE.....	1
HOW TO READ THIS DOCUMENT.....	1
REFERENCES.....	1
DESCRIPTION.....	3
DOCUMENT CONVENTIONS.....	4
Requirements numbering conventions:.....	4
Requirements language.....	4
METHODOLOGY.....	5
<b>1. USE CASE OVERVIEW</b> .....	<b>6</b>
1.1 SCOPE.....	6
1.2 USE CASE ACTORS AND SERVICES.....	7
1.3 DESIGN CONSTRAINTS AND ASSUMPTIONS.....	8
1.4 KEY CONCEPTS.....	9
<b>2. WORKFLOWS FOR TRANSFER AND REFERRALS</b> .....	<b>11</b>
2.1 TRANSFER.....	11
2.1.1 Initiate Transfer.....	12
2.1.2 Dispatch Transfer.....	13
2.1.3 Evaluate Bid.....	15
2.1.4 Evaluate Transfer.....	16
2.1.5 Information Requested.....	18
2.1.6 Process Transfer Response.....	18
2.1.7 Timeout on Transfer Response.....	20
2.1.8 Pending Transfer.....	22
2.1.9 Patient Admission.....	23
2.2 REFERRAL.....	24
2.2.1 Initiate Referral.....	25
2.2.2 Dispatch Referral.....	26
2.2.3 Evaluate Bid.....	28
2.2.4 Evaluate Referral.....	29
2.2.5 Information Requested.....	31
2.2.6 Process Referral Response.....	32
2.2.7 Timeout on Referral Response.....	34
2.2.8 Make Appointment.....	35
2.2.9 Pending Patient Arrival.....	36
2.2.10 Referral Services Initiated.....	37
2.3 DIRECT TRANSFER.....	38
2.3.1 Initiate Transfer.....	39
2.3.2 Evaluate Transfer.....	40

2.3.3	Information Requested .....	42
2.3.4	Process Direct Transfer Response .....	42
2.3.5	Pending Transfer .....	43
2.3.6	Patient Admission .....	44
2.4	<b>DIRECT REFERRAL .....</b>	<b>46</b>
2.4.1	Initiate Referral .....	46
2.4.2	Evaluate Referral.....	47
2.4.3	Information Requested .....	49
2.4.4	Process Direct Referral Response .....	50
2.4.5	Make Appointment.....	51
2.4.6	Pending Patient Arrival .....	51
2.4.7	Referral Services Initiated.....	52
2.5	<b>FLEXIBLE REFERRAL .....</b>	<b>53</b>
2.5.1	Initiate Referral .....	53
2.5.2	Make Appointment.....	54
2.5.3	Pending Patient Arrival .....	54
2.5.4	Referral Services Initiated.....	55
<b>3.</b>	<b>CORE INTEROPERABILITY SPECIFICATION REQUIREMENTS .....</b>	<b>57</b>
3.1	ACTOR MAPPING TO SAUDI eHEALTH INTEROPERABILITY SPECIFICATIONS .....	57
3.2	INTEROPERABILITY SEQUENCE DIAGRAMS .....	68
3.2.1	Sequence diagram pre-conditions .....	68
3.2.2	Other sequence diagram requirements .....	70
3.2.3	Main flow sequence diagrams.....	72
3.2.4	Alternate flow sequence diagrams .....	78
<b>4.</b>	<b>REFERRAL WORKFLOW ACTOR CONFORMANCE.....</b>	<b>84</b>
4.1	TRANSFER REQUESTER CONFORMANCE .....	84
4.2	REFERRAL REQUESTER CONFORMANCE .....	86
4.3	WORKFLOW MANAGER CONFORMANCE.....	88
4.4	REFERRAL/TRANSFER RECEIVER CONFORMANCE .....	90
4.5	HIE DOCUMENT REPOSITORY CONFORMANCE .....	92
<b>5.</b>	<b>SAUDI EHEALTH CONSTRAINTS ON THE REFERRAL WORKFLOW.....</b>	<b>95</b>
5.1	GENERAL WORKFLOW PARTICIPANT ACTOR RESPONSIBILITIES .....	95
5.1.1	Workflow Identifiers .....	95
5.1.2	Document Metadata and Conformance Requirements .....	96
5.2	TRANSFER REQUESTER .....	100
5.2.1	General Requirements.....	100
5.2.2	In the Transfer Workflow: .....	100
5.2.3	In the Direct Transfer Workflow: .....	101
5.3	REFERRAL REQUESTER .....	102
5.3.1	General Requirements.....	102

5.3.2	In the Referral Workflow: .....	102
5.3.3	In the Direct Referral Workflow: .....	103
5.3.4	In the Flexible Referral Workflow: .....	104
5.4	WORKFLOW MANAGER .....	104
5.4.1	General Requirements .....	104
5.4.2	In the Transfer Workflow: .....	104
5.4.3	In the Referral Workflow: .....	107
5.5	REFERRAL/TRANSFER RECEIVER .....	111
5.5.1	General Requirements .....	111
5.5.2	In the Transfer Workflow: .....	111
5.5.3	In the Referral Workflow: .....	113
5.5.4	In the Direct Transfer Workflow: .....	116
5.5.5	In the Direct Referral Workflow: .....	118
5.5.6	In the Flexible Referral Workflow: .....	120
<b>6.</b>	<b>REFERENCED DOCUMENTS AND STANDARDS .....</b>	<b>122</b>
6.1	COPYRIGHT PERMISSIONS .....	124
<b>7.</b>	<b>APPENDIX A: SAMPLE MESSAGES .....</b>	<b>125</b>

## LIST OF TABLES

TABLE 1.2-1 USE CASE ACTORS.....	7
TABLE 1.2-2 USE CASE SERVICES .....	8
TABLE 2.1-1TRANSFER WORKFLOW ACTIVITIES .....	11
TABLE 2.2-1REFERRAL WORKFLOW ACTIVITIES.....	24
TABLE 2.3-1DIRECT TRANSFER WORKFLOW ACTIVITIES.....	38
TABLE 2.4-1DIRECT REFERRAL WORKFLOW ACTIVITIES.....	46
TABLE 2.5-1FLEXIBLE REFERRAL WORKFLOW ACTIVITIES .....	53
TABLE 3.1-1 INTEROPERABILITY CONFORMANCE REQUIREMENTS FOR TRANSFER REQUESTER .....	57
TABLE 3.1-2 INTEROPERABILITY CONFORMANCE REQUIREMENTS FOR REFERRAL REQUESTER.....	59
TABLE 3.1-3 INTEROPERABILITY CONFORMANCE REQUIREMENTS FOR WORKFLOW MANAGER.....	62
TABLE 3.1-4 INTEROPERABILITY CONFORMANCE REQUIREMENTS FOR REFERRAL/TRANSFER RECEIVER .....	64
TABLE 3.1-5 INTEROPERABILITY CONFORMANCE REQUIREMENTS FOR HIE DOCUMENT REPOSITORY .....	67
TABLE 6-1 INTERNAL REFERENCES.....	122
TABLE 6-2 EXTERNAL REFERENCES.....	123

## LIST OF FIGURES

FIGURE 0-1 REFERRAL AND TRANSFER WORKFLOW DOCUMENT ORGANIZATION.....	3
FIGURE 3.2-1 PRE-CONDITION SEQUENCE DIAGRAM.....	69
FIGURE 3.2-2 TRANSACTIONS ASSOCIATED WITH A REGISTRY STORED QUERY.....	70
FIGURE 3.2-3 TRANSACTIONS ASSOCIATED WITH A DOCUMENT RETRIEVAL .....	71
FIGURE 3.2-4 TRANSACTIONS ASSOCIATED WITH PUBLISH DOCUMENT.....	72
FIGURE 3.2-1 TRANSACTIONS SIMPLE COLLABORATION CIRCLE BASED TRANSFER (1).....	74
FIGURE 3.2-2 TRANSACTIONS SIMPLE COLLABORATION CIRCLE BASED TRANSFER (2).....	76
FIGURE 3.2-3 TRANSACTIONS SIMPLE COLLABORATION CIRCLE BASED TRANSFER (3).....	78
FIGURE 3.2-12 TRANSACTIONS ASSOCIATED WITH DIRECTED REFERRAL (1).....	81
FIGURE 3.2-3 TRANSACTIONS ASSOCIATED WITH DIRECTED REFERRAL (2).....	83

CONFIDENTIALITY STATEMENT:

The Ministry of Health (MOH) of the Kingdom of Saudi Arabia grants to any user of this document, perpetual, royalty-free, nontransferable, nonexclusive, license under its copyrights to access and read the Saudi eHealth Specification. You may not reproduce or use this document or any portion of it, without prior written consent from the MOH. The licenses covered are only to those parts owned or controlled by the MOH itself. If parts of the Saudi eHealth Specification include materials owned or controlled by other parties, licenses to use those products would have to be obtained from that other party.

The MOH offers the licensed material as-is and as-available, and makes no representations or warranties of any kind concerning the licensed material, whether express, implied, statutory, or other. This includes, without limitation, warranties of title, merchantability, fitness for a particular purpose, non-infringement, absence of latent or other defects, accuracy, or the presence or absence of errors, whether or not known or discoverable. To the extent possible, in no event will the authors and licensor be liable on any legal theory (including, without limitation, negligence) or otherwise for any direct, special, indirect, incidental, consequential, punitive, exemplary, or other losses, costs, expenses, or damages arising out of this public license or use of the licensed material, even if the licensor has been advised of the possibility of such losses, costs, expenses, or damages.

Document Revision History

Version	Date	Type of update	Prepared/Revised by
1.0	February 22, 2015	First Release	eHealth Strategy Management Office – eHealth Standards Department

## PREFACE

### DOCUMENT PURPOSE

The purpose of this document is to address the Saudi eHealth Core Interoperability Specifications for the UC0010 *Saudi eHealth eReferral and Transfer Use Case*. It forms a set of requirements that complements the set of Integrating the Healthcare Enterprise (IHE) Profiles, Health Level 7 (HL7) Vocabulary Standards required by this specification with Saudi eHealth specific constraints. It also aligns with the Saudi e-Government Interoperability Standards (YEFI) to expedite national adoption.

This Core Interoperability Specification is applicable to existing and new information systems that will connect to exchange Health Information. In particular this Interoperability Specification applies to the deployment of Health Information Exchange (HIE) Platforms such as the Saudi Health Exchange (SeHE).

### HOW TO READ THIS DOCUMENT

This document contains six sections, as well as informative appendices for your convenience. The document is structured as follows:

**Section 1:** Describes the Use Case, including design constraints and assumptions. Please refer to UC0010 *Saudi eHealth eReferral and eTransfer Use Case* for workflows.

**Section 2:** Describes the transfer and referral workflows that have been identified in the Use Case.

**Section 3:** Establishes the Core Interoperability Requirements for the Interoperability Specification

**Section 4:** Establishes the Conformance Requirements for the Interoperability Specification

**Section 5:** Establishes the Saudi eHealth Constraints on the *eReferral and eTransfer Use Cases*.

**Section 6:** Lists the Saudi eHealth reference documents, as well as the international standards which underpin the Interoperability Specification.

Appendix A: illustrates sample documents messages associated with eReferral and eTransfer.

### REFERENCES

The Saudi eHealth Interoperability Core Specification (IS) is the sole entry point for the technology developers, the compliance assessor/testers and certifiers, and the purchaser of IT systems in terms of technical requirements.

This Interoperability Specification references a number of other Core and Supporting Interoperability Specifications:

- IS0001 *Saudi eHealth Core Interoperability Specification for KSA-Wide Patient Demographic Query*



- IS0002 *Saudi eHealth Core IS for Healthcare Provider Directory Query*
- IS0007 *Saudi eHealth Core Interoperability Specification for Clinical Notes and Summaries*
- IS0101 *Saudi eHealth Security and Privacy Interoperability Specification*
- IS0102 *Saudi eHealth Document Sharing Interoperability Specification*
- IS0106 *Saudi eHealth Clinical Documents Constrains Interoperability Specifications*
- IS0200 *Saudi eHealth Terminology Repository*

The above Saudi eHealth Interoperability Specifications include precise references to internationally adopted profiles and standards as well as Saudi specific constraints.

This document fits into an overall specification framework described in Figure 0-1 Referral and Transfer workflow document organization. Further descriptions and references for the documents identified below are provided in Section 6 Referenced Documents and Standards.

Implementations are required to conform to the requirements within this Interoperability Specification; all Saudi eHealth referenced Interoperability Specifications and the standards and profiles they specify.

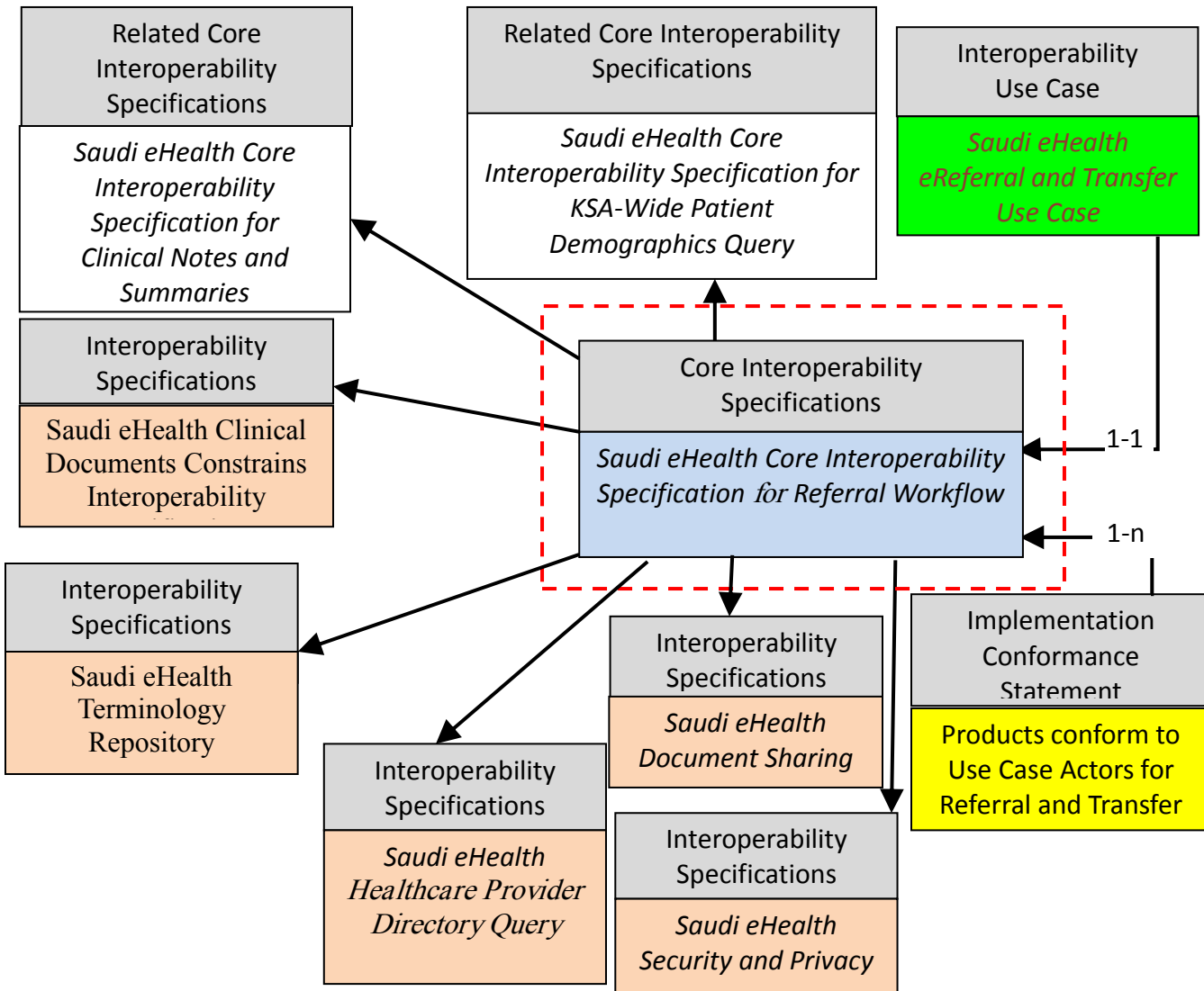

FIGURE 0-1 REFERRAL AND TRANSFER WORKFLOW DOCUMENT ORGANIZATION

**DESCRIPTION**

This Core Interoperability Specification describes the technical interface requirements to enable Healthcare Providers and facilities to electronically refer and/or transfer patients to other healthcare facilities. This includes KSA healthcare organizations, such as Primary Healthcare Centers (PHC), Hospitals, Specialty Centers, Long-term Care, etc. It covers MOH facilities but also other governmental organizations (such as National Guard and Military) and private healthcare systems. This information is published and is accessible via the Health Information Exchange (HIE). This enables access to the information by various “edge” applications including point of care systems and MOH business applications.

## DOCUMENT CONVENTIONS

### Requirements numbering conventions:

All Saudi eHealth Interoperability Specifications contain numbered requirements that follow this format:

- [ABCD-####], where ABCD is a three or four letter acronym unique to that Interoperability Specification for convenient purposes, and #### is the unique number for that requirement within the Interoperability Specification.
- “Where a specific value set or code is required to be used, it can be found in the “IS0200 Saudi eHealth Terminology Repository”. The location and process to access the terminology repository will be specified in mechanisms external to this document.

Saudi eHealth numbered requirements are the elements of the Interoperability Specification that the system shall conform to. In other words, in order to implement a system that fully supports the Use Case and Interoperability Specification, the system shall be able to demonstrate that it conforms to every numbered requirement for the system actors to which it is claiming conformance.

Please note that all Saudi eHealth numbered requirements are numbered uniquely, however numbered requirements may not always be sequential.

### Requirements language

Throughout this document the following conventions<sup>1</sup> are used to specify requirement levels:

**SHALL:** the definition is an absolute requirement of the specification.(Note: “SHALL IF KNOWN” means that the tag must be sent. However, if there were no information, then this tag should be sent with a <nullflavor>)

**SHALL NOT:** the definition is an absolute prohibition of the specification.

**SHOULD:** there may exist valid reasons in particular circumstances to ignore a particular item, but the full implications must be understood and carefully weighed before choosing a different course.

**SHOULD NOT:** there may exist valid reasons in particular circumstances when the particular behavior is acceptable or even useful, but the full implications should be understood and the case carefully weighed before implementing any behavior described with this label.

**MAY or OPTIONAL:** means that an item is truly optional. One vendor may choose to include the item because a particular marketplace requires it or because the vendor feels that it enhances the product while another vendor may omit the same item.

---

<sup>1</sup> Definitions based upon RFC 2119

## **METHODOLOGY**

This Interoperability Specification has been developed with input from various Saudi stakeholders collected during several months through workshops and teleconferences. Stakeholders included Physicians from many different disciplines and Saudi eHealth IT specialists.

The development of a Core Interoperability Specification relies on the high-level requirements set by the associated Use Case. These high-level requirements are not restated in this specification and readers may consider reviewing the related Use Case document.

## 1. USE CASE OVERVIEW

This section provides an overview of the Referral Workflow Use Case. For full details see UC0010 *Saudi eHealth eReferral and Transfer Use Case*.

This section describes the driving Use Case, including all design constraints and assumptions including the flows of information that will be specified in this document. This section also introduces the scenarios that describe how the specified workflows may be used in the Saudi eHealth context.

### 1.1 SCOPE

#### **In Scope:**

The scope of this document is the exchange of information necessary to transfer or refer a patient for care from one facility or provider to another.

The following topics are in scope for this Interoperability Specification:

- Referrals from any facilities (e.g. PHC, private doctor, hospital) to hospitals (out-patient).
- Referrals from any facilities to non-hospital facilities (PHC, specialized clinics, etc.)
- Hospital to Hospital Transfer (in-patient).
- Hospital to Long Term Care Transfer (in-patient).

Includes all KSA approved healthcare facilities, such as Ministry of Health (MOH) based facilities, Primary Health Care Centers, Medical Cities, Hospitals (governmental and private), private care clinics, National Guard, Military, etc.

The scope of this document is further constrained as follows:

- Patients may be referred or transferred so long as they have a KSA-Wide Health IDs (either permanent or temporary IDs)

*Note: Any person who is legally in Saudi Arabia may obtain a KSA-Wide Health ID.*

#### **Out of scope:**

The following is a list of content and specifications that are specifically out of scope for this Interoperability Specification:

- Transportation planning and choice of method of transport.
- Internal workflow to request and manage referrals and transfers within an organization.
- Internal workflow for the acceptance or rejection process of organizations receiving referrals and transfers.
- Internal workflow to manage the scheduling process of referred patients.
- The rules or any encoding of such business logic by which the workflow manager makes decisions about which responses to accept.
- The mechanism or process by which escalation is handled by the workflow manager.

- The workflow rules applied by the Workflow Managers within their Collaboration Circle.
- The mechanism of exchange of Clinical Notes and Summaries to be included with the referral or transfer, as this information can be found in IS0007 *Saudi eHealth Clinical Notes and Summaries Core Interoperability Specification*.
- The structure of Clinical Notes and Summaries to be exchanged, as this information can be found in other Interoperability Specifications such as IS0106 *Saudi eHealth Clinical Documents Constrains Interoperability Specifications*.  
The mechanism used to ensure that the Patient ID identifiers are consistent between the referral systems and the HIE Platform (which uses the KSA-Wide Health ID).
- The reconciliation of temporary KSA-Wide Health IDs to a patient's permanent KSA-Wide Health ID.
- User Interface requirements.

## 1.2 USE CASE ACTORS AND SERVICES

The Use Case Actors and the Services that are used by this Saudi eHealth Interoperability Referral Workflow Core Interoperability Specification are described at a functional level in UC0010 *Saudi eHealth eReferral and eTransfer Use Case* document. Readers that wish to understand the mapping of Use Case Actors to real world products are recommended to read UC0010 *Saudi eHealth eReferral and Transfer Use Case*. A summary is provided in the following tables.

TABLE 1.2-1 USE CASE ACTORS

USE CASE ACTOR NAME	DESCRIPTION
Referral Requester	Initiates referrals of patients to other providers, and for responding to notifications of acceptance or rejection of those referrals.
Transfer Requester	Initiates transfers of patients to other facilities (i.e. hospital and long term care), and for responding to notifications of acceptance or rejection of those transfers.
Workflow Manager	Manages transmission of referral and transfer requests to appropriate facilities and arbitrating and managing requests based on established referral and transfer policies.
Referral/Transfer Receiver	Receives referral and transfer requests, and responding to them appropriately.
HIE Document Repository	Stores documents such as referral and/or transfer requests and responses. It also provides access to related information about the patient and/or about the patient's medical documentation. This actor includes the HIE Document Registry

How actual implementations support Use Case Actors may vary. For example, some implementations may support a Use Case Actor entirely by a single system design. Other implementations may support a Use Case Actor using a gateway system integrated with the point of service system.

The typical implementation architecture aligns the Use Case Actors capabilities as defined in this Interoperability Specification with a single system or integrated set of systems under the design and responsibility of one vendor.

In specific implementation situations the vendor boundary does not align with the Use Case Actor. For example, a point of care system is from one vendor, while a gateway system which converts the point of care system to the Use Case Actor is from a different vendor. The interface between the two systems is not specified by this Interoperability Specification and is the responsibility of the implementation project.

TABLE 1.2-2 USE CASE SERVICES

SERVICE NAME	DESCRIPTION
Manage Referral or Transfer	Create and manage referral and transfer workflow documents in the HIE Document Repository and request that it stores these documents and register their metadata.
Query/Retrieve Documents	Used by Actors to query the HIE Document Repository for information about documents stored and indexed by metadata and retrieve one or more relevant documents.
Publish Document(s)	Used by Actors to provide a set of documents to the HIE Document Repository and to request that it stores these documents and register their metadata.
Notification of Document Availability	Provided by the HIE Document Repository to notify other actors that a workflow document of interest is available to be retrieved.

### 1.3 DESIGN CONSTRAINTS AND ASSUMPTIONS

The following design principles underlie this Interoperability Specification:

- It is expected that all services initiated or provided by these Actors operate in accordance to the Saudi Health Information Exchange Policies.
- Temporary KSA-Wide Health IDs can be created to enable transfers or referrals of patients who cannot be identified prior to transfer.
- A permanent KSA-Wide Health ID can be created for a newborn.
- It is the responsibility of the receiving system (Referral/Transfer Receiver) to reconcile their local patient IDs and any other coded data elements with the KSA-Wide Health ID, and nationally specified coded data as well as other coded information in the attached clinical notes, summaries or reports.
- Configuration of the Document Metadata Subscription to enable receipt of notifications is expected to happen at installation/configuration time. This means that as Point Of Care Systems (e.g. new Hospital HIS, new PHC EMR) are added to the HIE, they need to be manually configured to be able to receive document notification. This simplifies implementation until specific need for dynamic subscription has been identified. For further details, see the IS0102 *Saudi eHealth Document Sharing Interoperability Specification*.

- Along with the Workflow document, a set of required metadata has to be created by the Referral Requester or the Transfer Requester and recorded in the HIE Document Repository in order to allow the Workflow Manager or Referral/Transfer Receiver to select relevant workflow and attached documents.

## 1.4 KEY CONCEPTS

**Bidding:** A mode of operation in processing a referral or transfer whereby the choice between the referral or transfer sites is made by the Workflow Manager based upon details (e.g., terms of service) provided in the Referral/Transfer Response Document.

Note: In cases there are several positive responses to a bid, the patient may be engaged in the decision process to select among these responses through the Workflow Manager.

**Collaboration Circle:** A collection of workflow participants (Referral Requesters, Transfer Requester and Referral/Transfer Receivers) that request and perform referrals or transfers of patients. Collaboration Circles have a number of properties:

- A Collaboration Circle shall include one or more Referral Requester or/and or Transfer Requester actors.
- A Collaboration Circle shall include one Workflow Manager.
- A Collaboration Circle is identified by the identifier of its Workflow Manager.

**Referral:** A workflow in which a physician chooses to refer a patient for a consultation or diagnosis service for which the requesting physician needs to receive a response

**Referral Request Document:** The Referral Request Document is described in Section 5.12 of IS0106 *Saudi eHealth Clinical Documents Constrains Interoperability Specifications*. This document provides the details about the Referral Request.

**Referral/Transfer Response Document:** The Referral/Transfer Response Document is described in Section 5.13 of IS0106 *Saudi eHealth Clinical Documents Constrains Interoperability Specifications*. This document provides the details about the Referral or Transfer Response referred to as the Referral Response Document in Referral Workflows and the Transfer Response Document in Transfer Workflows.

**Reassignment:** The reassignment of a Referral or Transfer Request is an action taken by a Workflow Manager as part of its dispatching task to direct a Referral or Transfer Request outside its Collaboration Circle. The Workflow Manager dispatches the request to another Collaboration Circle, to which it reassigns all of its responsibilities.

**Transfer** A workflow that seeks to move a patient currently treated in a health facility to other healthcare facilities where the treatment should be continued.

**Transfer Request Document:** The Transfer Request Document is described in Section 5.12 of IS0106 *Saudi eHealth Clinical Documents Constrains Interoperability Specifications*. This document provides the details about the Transfer Request.

**Workflow Participant Identifier:** Workflow participants Actors (Referral Requesters, Transfer Requester, Referral/Transfer Receivers and Workflow Managers) trigger notifications to each other during the execution of a referral or transfer workflow by using their Workflow Participant Actor Identifier.



**Workflow Manager:** One of the Workflow Participant responsible to dispatch the Referral and Transfer requests to the most suitable Workflow recipients in the Collaboration Circle based on rules that have been agreed by all participants to the Collaboration Circle. It selects the best choice from those responses received and informs the selected recipient and the requester.

## 2. WORKFLOWS FOR TRANSFER AND REFERRALS

The five workflows described in more detail below have been defined to support the variety of referral and transfer workflows that have been identified in the UC0010 *Saudi eHealth eReferral and eTransfer Use Case* document. The IHE Cross Enterprise Document Workflow (XDW) Profile describes an artifact (the Workflow Document) which provides the current state of a workflow. The Workflow Document describes all tasks created, being processed, completed or failed by the workflow participants in an instance of the workflow. For this Interoperability Specification, the main Use Case Actors have been mapped to XDW Workflow Participants. The HIE Document Repository actor described in this document is part of the HIE Platform infrastructure supporting workflow, but is not a “workflow participant” in the IHE XDW profile.

These workflows are defined in more detail in the sections below. Each subsection begins with a short description of the workflow, followed by a table describing it. The table enumerates the steps in the business processes in the first column. These steps are performed by the Use Case Actor in the second column (actors described in section 1.2 Use Case Actors and Services). The final column describes what happens next in this workflow.

Although not explicitly mentioned at each step of each workflow, the HIE Platform will be used to issue notifications to workflow participants where the workflow step requires participant action for completion may require action.

### 2.1 TRANSFER

The Transfer Workflow allows a physician to request a transfer from members of a Collaboration Circle. Upon making the request, the workflow manager for that Collaboration Circle selects one or more hospitals to which the transfer could be routed. These hospitals respond with their ability to accept the transfer. The workflow manager then selects the best choice from those responses and the transfer is initiated.

TABLE 2.1-1 TRANSFER WORKFLOW ACTIVITIES

STEP	ACTOR	NEXT STEP
1. Initiate Transfer	Transfer Requester	Go to Dispatch Transfer.
2. Dispatch Transfer	Workflow Manager	If no bidding is needed go to Evaluate Transfer. If bidding is needed go to Evaluate Bid. If transferring to another circle go to Dispatch Transfer. If cannot dispatch because no receivers are available this workflow is completed and has failed.
3. Evaluate Bid	Referral/Transfer Receiver	If bidding not acceptable go to Process Transfer Response. If bidding acceptable go to Evaluate Transfer.
4. Evaluate Transfer	Referral/Transfer Receiver	If more information is needed go to Information Requested. If no need for more information and can handle the transfer go to Process Transfer Response. If no need for more information and cannot handle the transfer go to Process Transfer Response. If more information is needed and the information request

		times out, this workflow is completed and has failed. If transfer is cancelled this workflow is completed and has failed.
5. Information Requested	Transfer Requester	Go to Evaluate Transfer.
6. Process Transfer Response	Workflow Manager	If an acceptable response has been received go to Pending Transfer. If no acceptable response has been received and no responses pending and escalation possible go to Pending Transfer. If no acceptable response has been received and no responses pending and escalation possible this workflow is completed and has failed. If no acceptable response has been received and no responses are pending and no escalation is possible this workflow is completed and has failed.
7. Timeout on Transfer Response	Workflow Manager	If can resolve through escalation go to Pending Transfer. If cannot resolve through escalation this workflow is completed and has failed.
8. Pending Transfer	Transfer Requester	If patient transport is initiated go to Patient Admission. If patient transport is not initiated this workflow is completed and has failed.
9. Patient Admission	Referral/Transfer Receiver	If the patient's admission is completed within reasonable time frame this workflow is completed and has succeeded. If the patient's admission is completed at a different hospital this workflow is completed and has succeeded. If the patient's admission is not completed at a different hospital and was not completed within reasonable time frame this workflow is completed and has failed.

### 2.1.1 Initiate Transfer

In this Step, the Transfer Requester Actor initiates a transfer by creating the Transfer Request task, providing references to relevant Clinical Documents (e.g., Encounter Summary, Discharge Summary, Lab Result Report, Imaging Report, et cetera) and the Transfer Request Document.

#### 2.1.1.1 Triggers

- The Patient requires a Transfer

#### 2.1.1.2 Actions

The Transfer Requester:

1. Publishes any supporting documents that have not already been shared in including the HIE Infrastructure.
  - a. Ensures that the **Relevant Clinical documents** are published.

- b. Ensures that the **Transfer Request Document** is published.
2. Creates a new Request Transfer Task.
  - a. The status of the task is set to COMPLETED.
  - b. The task is assigned to the Transfer Requester itself.
  - c. Adds a reference to the **Relevant Clinical documents** to the **Input Documents** for the task.
  - d. Adds a reference to the **Transfer Request Document** to the **Output Documents** for the task.

### 2.1.2 Dispatch Transfer

This step is initiated by Workflow Manager to dispatch the transfer to one or more Referral/Transfer Receiver actors within its Collaboration Circle. The Workflow Manager creates a Respond to Transfer Request or Bid on a Transfer Request Task for each of these actors in its Collaboration Circle and they are then notified of the new task depending upon the need for bidding in this Collaboration Circle. It then creates a Dispatch Transfer Task in the COMPLETED state to note that the transfer has been dispatched.

When there is only one organization to which the transfer can be assigned, this task is still used to negotiate the details of the transfer (e.g., identify necessary resources, available appointment times, et cetera). When there are multiple organizations that could be assigned, how the Workflow Manager decides upon which organizations are given the opportunity to respond is left up to the configuration of the Workflow Manager and is outside of the scope of this specification.

#### 2.1.2.1 Triggers

- Dispatch Transfer READY

#### 2.1.2.2 Actions

##### *2.1.2.2.1 No Bidding is Needed*

The Workflow Manager:

1. Publishes any supporting referenced documents that have not already been shared in the HIE Infrastructure.
  - a. Ensures that the **Transfer Request Document** is published.
  - b. Ensures that the **Relevant Clinical Documents** are published.
2. Creates a new Respond to a Transfer Request Task.

A Respond to a Transfer Request is created for each Referral/Transfer Receiver actor selected by the Workflow Manager to respond to this request.

- a. The status of the task is set to READY.
- b. The task is assigned to the Referral/Transfer Receiver.
- c. Adds a reference to the **Transfer Request Document** to the **Input Documents** for the task.
- d. Adds a reference to the **Relevant Clinical documents** to the **Input Documents** for the task.

#### ***2.1.2.2.2 Bidding is Needed***

The Workflow Manager may determine that this Collaboration Circle requires transfers to be bid upon.

Note: Members of a Collaboration Circle that do not support bidding should respond to a Bid on Transfer Request with an indication that they cannot accept transfers that require bidding.

The Workflow Manager:

1. Publishes any supporting referenced documents that have not already been shared in the HIE Infrastructure.
  - a. Ensures that the **Transfer Request Document** is published.
2. Transitions the Dispatch Transfer Task to COMPLETED.
  - a. Adds a reference to the **Transfer Request Document** to the **Output Documents** for the task.
3. Publishes any supporting referenced documents that have not already been shared in the HIE Infrastructure.
  - a. Ensures that the **Transfer Request Document** is published.
  - b. Ensures that the **Relevant Clinical documents** are published.
4. Creates a new Bid on a Transfer Request Task.
  - a. The status of the task is set to READY.
  - b. The task is assigned to the Referral/Transfer Receiver.
  - c. Adds a reference to the **Transfer Request Document** to the **Input Documents** for the task.
  - d. Adds a reference to the **Relevant Clinical documents** to the **Input Documents** for the task.

#### ***2.1.2.2.3 Reassigning to another Circle***

In some cases, the Workflow Manager may need to reassign the request to another Collaboration Circle. To do so, it simply sets the Workflow Manager owning the Dispatch Transfer task to the Workflow Manager responsible for managing that Collaborator Circle.

The Workflow Manager:

1. Reassigns the Dispatch Transfer Task to another Workflow Manager.

#### ***2.1.2.2.4 Cannot Dispatch because no Receivers are available***

There may be cases where the Referral/Transfer Receivers of a Collaboration Circle cannot respond (e.g., due to natural disaster or other exceptional cases). In these cases, the Workflow Manager may simply fail the request.

The Workflow Manager:

1. Publishes any supporting referenced documents that have not already been shared in the HIE Infrastructure.
  - a. Ensures that the **Transfer Request Document** is published.

2. Transitions the Dispatch Transfer Task to FAILURE.
  - a. Adds a reference to the **Transfer Request Document** to the **Output Documents** for the task.
  - b. The Workflow is marked as CLOSED and has Failed.
3. Publishes any supporting referenced documents that have not already been shared in the HIE Infrastructure.
  - a. Ensures that the **Relevant Clinical documents** are published.
  - b. Ensures that the **Transfer Request Document** is published.
4. Transitions the Request Transfer Task to FAILURE.
  - a. Adds a reference to the **Relevant Clinical documents** to the **Input Documents** for the task.
  - b. Adds a reference to the **Transfer Request Document** to the **Output Documents** for the task.
  - c. The Workflow is marked as CLOSED and has Failed.

### **2.1.3 Evaluate Bid**

The Referral/Transfer Receiver must determine whether or not to bid on a transfer when it has been assigned through the Bid on Transfer Task. If it determines that a bid will be made the workflow would transition to the Respond to Transfer Task, otherwise the workflow fails.

#### **2.1.3.1 Triggers**

- Bid on a Transfer Request READY

#### **2.1.3.2 Actions**

##### ***2.1.3.2.1 Bidding not acceptable***

If bids are not processed by this receiver, the task can be failed.

The Referral/Transfer Receiver:

1. Transitions the Bid on a Transfer Request Task to FAILURE.

##### ***2.1.3.2.2 Bidding acceptable***

If bids are processed by this receiver, the task is completed and a response can be generated.

The Referral/Transfer Receiver:

1. Transitions the Bid on a Transfer Request Task to COMPLETED.
2. Publishes any supporting referenced documents that have not already been shared in the HIE Infrastructure.
  - a. Ensures that the **Transfer Request Document** is published.
  - b. Ensures that the **Relevant Clinical documents** are published.
3. Creates a new Respond to a Transfer Request Task.

The Respond to a Transfer Request task is created to signal that the Referral/Transfer Receiver is ready to respond to this request.

- a. The status of the task is set to READY.
- b. The task is assigned to the Referral/Transfer Receiver itself.
- c. Adds a reference to the **Transfer Request Document** to the **Input Documents** for the task.
- d. Adds a reference to the **Relevant Clinical documents** to the **Input Documents** for the task.

#### **2.1.4 Evaluate Transfer**

The Referral/Transfer Receiver must evaluate a transfer when it has been assigned through the Respond to Transfer Task, or when more information about it has been provided. It processes the Transfer and responds in one of three ways:

##### **2.1.4.1 Triggers**

- Respond to a Transfer Request READY
- Request Information COMPLETED

##### **2.1.4.2 Actions**

###### ***2.1.4.2.1 More Information is Needed***

If, during the processing of the request, the Referral/Transfer Receiver Actor determines that more information is needed (e.g., patient status information, lab results, etc.), it can be requested.

The Referral/Transfer Receiver:

1. Publishes any supporting referenced documents that have not already been shared in the HIE Infrastructure.
  - a. Ensures that the **Information Request Document** is published.
2. Creates a new Request Information Task.
  - a. The status of the task is set to READY.
  - b. The task is assigned to the Transfer Requester.
  - c. Adds a reference to the **Information Request Document** to the **Input Documents** for the task.

###### ***2.1.4.2.2 No Need for More Information and CAN handle the Transfer***

If the Transfer can be accepted, the Receiver should provide details about resources and services available in the response document.

The Referral/Transfer Receiver:

1. Publishes any supporting referenced documents that have not already been shared in the HIE Infrastructure.

- a. Ensures that the **Transfer Request Document** is published.
  - b. Ensures that the **Relevant Clinical documents** are published.
  - c. Ensures that the **Referral/Transfer Response Document** is published.
2. Transitions the Respond to a Transfer Request Task to COMPLETED.
    - a. Adds a reference to the **Transfer Request Document** to the **Input Documents** for the task.
    - b. Adds a reference to the **Relevant Clinical documents** to the **Input Documents** for the task.
    - c. Adds a reference to the **Referral/Transfer Response Document** to the **Output Documents** for the task.

#### ***2.1.4.2.3 No Need for More Information and CANNOT handle the Transfer***

If the Transfer cannot be accepted, the receiver should describe the reason why the transfer cannot be accepted in the Referral/Transfer Response Document (e.g., lack of resources).

The Referral/Transfer Receiver:

1. Publishes any supporting referenced documents that have not already been shared in the HIE Infrastructure.
  - a. Ensures that the **Transfer Request Document** is published.
  - b. Ensures that the **Relevant Clinical documents** are published.
  - c. Ensures that the **Referral/Transfer Response Document** is published.
2. Transitions the Respond to a Transfer Request Task to FAILURE.
  - a. Adds a reference to the **Transfer Request Document** to the **Input Documents** for the task.
  - b. Adds a reference to the **Relevant Clinical documents** to the **Input Documents** for the task.
  - c. Adds a reference to the **Referral/Transfer Response Document** to the **Output Documents** for the task.

#### ***2.1.4.2.4 Timeout occurs waiting for more information***

If the Transfer Requester does not respond to a request for more information in a timely fashion, the receiver should indicate that the transfer cannot be accepted due to a lack of response to the request for more information.

The Referral/Transfer Receiver:

1. Publishes any supporting referenced documents that have not already been shared in the HIE Infrastructure.
  - a. Ensures that the **Referral/Transfer Response Document** is published.
2. Transitions the Request Transfer Task to FAILURE.
  - a. Adds a reference to the **Referral/Transfer Response Document** to the **Output Documents** for the task.
  - b. The Workflow is marked as CLOSED and has Failed

#### ***2.1.4.2.5 Transfer is Cancelled***

If the Transfer Requester cancels the request, the transfer has failed.



The Referral/Transfer Receiver:

1. Publishes any supporting referenced documents that have not already been shared in the HIE Infrastructure.
  - a. Ensures that the Referral/Transfer Response Document is published.
2. Transitions the Request Transfer Task to FAILURE.
  - a. Adds a reference to the Referral/Transfer Response Document to the Output Documents for the task.
  - b. The Workflow is marked as CLOSED and has Failed

### **2.1.5 Information Requested**

A Request Information Task is created by the Referral/Transfer Receiver Actor to request more information. The Requester is assigned to this task.

The Referral Requester will provide the requested information as an Output Document on the task and mark the task as being COMPLETED. The Workflow Manager will then notify the creator of the Request Information Task that it is finished, allowing the Referral/Transfer Receiver to determine how it should handle the Transfer request.

#### **2.1.5.1 Triggers**

- Request Information READY

#### **2.1.5.2 Actions**

The Transfer Requester:

1. Publishes any supporting referenced documents that have not already been shared in the HIE Infrastructure.
  - a. Ensures that the **Information Response Document AND/OR Relevant Clinical Documents** is published.
2. Transitions the Request Information Task to COMPLETED.
  - a. Adds a reference to the **Information Response Document AND/OR Relevant Clinical Documents** to the **Output Documents** for the task.

### **2.1.6 Process Transfer Response**

The Workflow Manager evaluates responses to determine whether it has received sufficient responses to process the transfer. If it is able to make a determination about assignment, it creates an assign transfer task to indicate that the transfer has been assigned to an organization. A Referral/Transfer Response Document will be attached as an Output Document. This Referral/Transfer Response Document may be one of the Referral/Transfer Response Documents provided by a Referral/Transfer Receiver, or it may be constructed by the Workflow Manager (e.g., in cases where it has escalated the request to make a decision). How the Workflow Manager makes a determination of which response to select is left up to the configuration of the

Workflow Manager. If no organization accepts the transfer, the Workflow Manager may still make an assignment. The rules governing how a Workflow Manager makes decisions is outside of the scope of this specification. If for some reason the Workflow Manager is not able to make an assignment decision, then it will mark the Assign Transfer Task as being FAILED and notify the original Transfer Requester. All Referral/Transfer Receivers that were asked to respond to the Transfer Request must be notified of the results of an assignment so that they can update any resources reservations that may have been made in response to the request, regardless of whether they were the selected receiver.

### **2.1.6.1 Triggers**

- Respond to a Transfer Request FAILURE
- Respond to a Transfer Request COMPLETED
- Bid on a Transfer Request FAILURE

### **2.1.6.2 Actions**

#### ***2.1.6.2.1 An Acceptable Response has been Received***

The Workflow Manager will determine what makes for an acceptable response. Once an acceptable response has been received and the Transfer site selected, All Referral/Transfer Receivers are notified so that any resource reservations can be appropriately updated.

The Workflow Manager:

1. Publishes any supporting referenced documents that have not already been shared in the HIE Infrastructure.
  - a. Ensures that the **Referral/Transfer Response Document** is published.
2. Creates a new Perform Transfer Task.
  - a. The status of the task is set to READY.
  - b. The task is assigned to the Workflow Manager itself.
  - c. Adds a reference to the **Referral/Transfer Response Document** to the **Output Documents** for the task.

#### ***2.1.6.2.2 No acceptable response has been received, but some responses still are pending.***

When no acceptable response has yet been received, but more responses are expected, the Workflow Manager simply waits for another response or for this task to time out.

#### ***2.1.6.2.3 No acceptable response has been received and no responses pending and escalation possible***

When no acceptable responses have been received and no more are expected, the Workflow Manager may use escalation to make an assignment. All Referral/Transfer Receiver actors are notified because they may have resources whose reservations need to be updated.

The Workflow Manager:

1. Publishes any supporting referenced documents that have not already been shared in the HIE Infrastructure.
  - a. Ensures that the **Transfer Response Document** is published.
2. Creates a new Perform Transfer Task.
  - a. The status of the task is set to READY.
  - b. The task is assigned to the Workflow Manager itself.
  - c. Adds a reference to the **Referral/Transfer Response Document** to the **Output Documents** for the task.
3. Publishes any supporting referenced documents that have not already been shared in the HIE Infrastructure.
  - a. Ensures that the **Relevant Clinical documents** are published.
  - b. Ensures that the **Transfer Request Document** is published.
4. Transitions the Request Transfer Task to FAILURE.
  - a. Adds a reference to the **Relevant Clinical documents** to the **Input Documents** for the task.
  - b. Adds a reference to the **Transfer Request Document** to the **Output Documents** for the task.
  - c. The Workflow is marked as CLOSED and has Failed

#### ***2.1.6.2.4 No acceptable response has been received and no responses are pending and no escalation is possible***

If escalation is not possible, then the Workflow Manager should fail the workflow. All Referral/Transfer Receiver actors are notified because they may have resources whose reservations need to be updated.

The Workflow Manager:

1. Publishes any supporting referenced documents that have not already been shared in the HIE Infrastructure.
  - a. Ensures that the **Referral/Transfer Response Document** is published.
2. Creates a new Perform Transfer Task.
  - a. The status of the task is set to FAILURE.
  - b. The task is assigned to the Workflow Manager itself.
  - c. Adds a reference to the **Referral/Transfer Response Document** to the **Output Documents** for the task.
  - d. The Workflow is marked as CLOSED and has Failed

#### **2.1.7 Timeout on Transfer Response**

When no acceptable responses have been received within an adequate time period, the Workflow Manager must make a determination how to handle the request. It may escalate the transfer request to ensure that a response is provided, or it may mark the request as having failed.

All Referral/Transfer Receivers must be notified of the FAILURE so that they can update any resources reservations that may have been made in response to the request.

### 2.1.7.1 Triggers

- Respond to Transfer Request
- Bid on a Transfer Request Timeout

### 2.1.7.2 Actions

#### ***2.1.7.2.1 Can resolve through escalation***

When insufficient responses have been received but the Workflow Manager is able to resolve the transfer through escalation, it will create the Perform Transfer task and assign it.

The Workflow Manager:

1. Publishes any supporting referenced documents that have not already been shared in the HIE Infrastructure.
  - a. Ensures that the **Referral/Transfer Response Document** is published.
2. Creates a new Perform Transfer Task.
  - a. The status of the task is set to READY.
  - b. The task is assigned to the Workflow Manager itself.
  - c. Adds a reference to the **Referral/Transfer Response Document** to the **Output Documents** for the task.

#### ***2.1.7.2.2 Cannot resolve through escalation***

When insufficient responses have been received and the Workflow Manager is unable to resolve the referral through escalation the workflow will fail.

The Workflow Manager:

1. Publishes any supporting referenced documents that have not already been shared in the HIE Infrastructure.
  - a. Ensures that the **Referral/Transfer Response Document** is published.
2. Creates a new Perform Transfer Task.
  - a. The status of the task is set to FAILURE.
  - b. The task is assigned to the Workflow Manager itself.
  - c. Adds a reference to the **Referral/Transfer Response Document** to the **Output Documents** for the task.
  - d. The Workflow is marked as CLOSED and has Failed
3. Publishes any supporting referenced documents that have not already been shared in the HIE Infrastructure.
  - a. Ensures that the **Relevant Clinical documents** are published.
  - b. Ensures that the **Transfer Request Document** is published.
4. Transitions the Request Transfer Task to FAILURE.
  - a. Adds a reference to the **Relevant Clinical documents** to the **Input Documents** for the task.
  - b. Adds a reference to the **Transfer Request Document** to the **Output Documents** for the task.

- c. The Workflow is marked as CLOSED and has Failed

### 2.1.8 Pending Transfer

The next stage is for the Transfer Requester to report on the status of the transport of the patient to the transfer location.

#### 2.1.8.1 Triggers

- Perform Transfer READY

#### 2.1.8.2 Actions

##### *2.1.8.2.1 Patient transport is initiated*

If transport has begun the Perform Transfer Task should be changed to the IN\_PROGRESS state.

The Transfer Requester:

1. Publishes any supporting referenced documents that have not already been shared in the HIE Infrastructure.
  - a. Ensures that the **Appointment Document** is published.
  - b. Ensures that the **Transfer Request Document** is published.
  - c. Ensures that the **Referral/Transfer Response Document** is published.
2. Transitions the Perform Transfer Task to IN\_PROGRESS.
  - a. Adds a reference to the **Appointment Document** to the **Input Documents** for the task.
  - b. Adds a reference to the **Transfer Request Document** to the **Input Documents** for the task.
  - c. Adds a reference to the **Referral/Transfer Response Document** to the **Output Documents** for the task.

##### *2.1.8.2.2 Patient transport is not initiated*

If transport is canceled the Perform Transfer Task should be changed to the FAILURE state.

The Transfer Requester:

1. Publishes any supporting referenced documents that have not already been shared in the HIE Infrastructure.
  - a. Ensures that the **Referral/Transfer Response Document** is published.
2. Transitions the Perform Transfer Task to FAILURE.
  - a. Adds a reference to the **Referral/Transfer Response Document** to the **Output Documents** for the task.
  - b. The Workflow is marked as CLOSED and has Failed

## 2.1.9 Patient Admission

Once the patient is in transit, the Transfer/Referral Requester should report the status of the patient arrival.

### 2.1.9.1 Triggers

- Perform Transfer IN\_PROGRESS

### 2.1.9.2 Actions

#### ***2.1.9.2.1 The Patient's admission is completed within reasonable time frame***

When the patient arrives for the transfer the Perform Transfer Task should be changed to the COMPLETED state.

The Referral/Transfer Receiver:

1. Publishes any supporting referenced documents that have not already been shared in the HIE Infrastructure.
  - a. Ensures that the **Referral/Transfer Response Document** is published.
2. Transitions the Perform Transfer Task to COMPLETED.
  - a. Adds a reference to the **Referral/Transfer Response Document** to the **Input Documents** for the task.
  - b. The Workflow is marked as CLOSED and has Succeeded

#### ***2.1.9.2.2 The Patient's admission is completed at a different hospital***

This is an exceptional case. The Transfer/Referral Receiver actor associated with the admitting hospital may locate the transfer by querying workflow documents for the patient.

The Referral/Transfer Receiver:

1. Publishes any supporting referenced documents that have not already been shared in the HIE Infrastructure.
  - a. Ensures that the **Referral/Transfer Response Document** is published.
2. Transitions the Perform Transfer Task to COMPLETED.
  - a. Adds a reference to the **Referral/Transfer Response Document** to the **Input Documents** for the task.
  - b. The Workflow is marked as CLOSED and has Succeeded

#### ***2.1.9.2.3 The Patient's admission is not completed at a different hospital and was not completed within reasonable time frame***

The Referral/Transfer Receiver should first check to see if the patient was admitted elsewhere. This can be determined by checking the status of the workflow. If the workflow is not CLOSED,

it should indicate that the admission did not complete. Otherwise, the workflow must have been closed by another actor, indicating either a failed transfer, or a successful transfer somewhere else.

The Referral/Transfer Receiver:

1. Publishes any supporting referenced documents that have not already been shared in the HIE Infrastructure.
  - a. Ensures that the **Referral/Transfer Response Document** is published.
2. Transitions the Perform Transfer Task to FAILURE.
  - a. Adds a reference to the **Referral/Transfer Response Document** to the **Input Documents** for the task.
  - b. The Workflow is marked as CLOSED and has Failed

## 2.2 REFERRAL

The Referral Workflow allows a physician to request a referral from members of a Collaboration Circle. Upon making the request, the workflow manager for that Collaboration Circle selects one or more hospitals to which the referral could be routed. These hospitals respond with their ability to accept the referral. The workflow manager then selects the best choice from those responses and the referral is made.

TABLE 2.2-1 REFERRAL WORKFLOW ACTIVITIES

STEP	ACTOR	NEXT STEP
1. Initiate Referral	Referral Requester	Go to Dispatch Referral.
2. Dispatch Referral	Workflow Manager	If receivers are available and no bidding is needed go to Evaluate Referral. If receivers are available and bidding is needed go to Evaluate Bid. If cannot dispatch because no receivers are available this workflow is completed and has failed.
3. Evaluate Bid	Referral/Transfer Receiver	If bids are processed by this receiver go to Evaluate Workflow. If bids are not processed by this receiver go to Process Referral Response.
4. Evaluate Referral	Referral/Transfer Receiver	If more information is needed go to Information Requested. If no need for more information and can handle the referral go to Process Referral Response. If no need for more information and cannot handle the referral go to Process Referral Response. If timeout occurs waiting for more information this workflow is completed and has failed. If the request is cancelled this workflow is completed and has failed.
5. Information Requested	Referral Requester	Go to Evaluate Referral.

6. Process Referral Response	Workflow Manager	If an acceptable response has been received go to Make Appointment. If no acceptable response is pending and can resolve through escalation go to Make Appointment. If no acceptable response is pending and cannot resolve through escalation this workflow is completed and has failed.
7. Timeout on Referral Response	Workflow Manager	If can resolve through escalation go to Make Appointment. If cannot resolve through escalation this workflow is completed and has failed.
8. Make Appointment	Referral/Transfer Receiver	Go to Pending Patient Arrival.
9. Pending Patient Arrival	Referral/Transfer Receiver	If the referral occurs within a reasonable time frame go to Referral Services Initiated. If the patient arrives at another organization for the referral rather than the one selected go to Referral Services Initiated. If the referral does not occur within a reasonable time frame and another organization has not already started the referral this workflow is completed and has failed.
10. Referral Services Initiated	Referral/Transfer Receiver	If the referral completes successfully this workflow is completed and has succeeded. If the referral did not complete successfully this workflow is completed and has failed.

### 2.2.1 Initiate Referral

In this step, the Referral Requester Actor initiates a referral by creating the Referral Request task, providing references to relevant Clinical Documents (e.g., Encounter Summary, Discharge Summary, Lab Result Report, Imaging Report, et cetera) and the Referral Request Document.

#### 2.2.1.1 Triggers

- The Patient Needs a Referral

#### 2.2.1.2 Actions

The Referral Requester:

1. Publishes any supporting referenced documents that have not already been shared in the HIE Infrastructure.
  - a. Ensures that the **Relevant Clinical documents** are published.
  - b. Ensures that the **Referral Request Document** is published.
2. Creates a new Request Referral Task.
  - a. The status of the task is set to **COMPLETED**.
  - b. The task is assigned to the Referral Requester itself.
  - c. Adds a reference to the **Relevant Clinical documents** to the **Input Documents** for the task.
  - d. Adds a reference to the **Referral Request Document** to the **Output Documents** for the task.



## 2.2.2 Dispatch Referral

This step is initiated by Workflow Manager to dispatch the referral to one or more Referral/Transfer Receiver actors within its Collaboration Circle. The Workflow Manager creates a Respond to Referral Request or Bid on Referral Request Task for each of these actors in its Collaboration Circle and they are then notified of the new task depending upon the need for bidding in this Collaboration Circle. It then creates a Dispatch Referral Task in the COMPLETED state to note that the referral has been dispatched.

When there is only one organization to which the referral can be assigned, this task is still used to negotiate the details of the referral (e.g., identify necessary resources, available appointment times, et cetera). When there are multiple organizations that could be assigned, how Workflow Manager decides upon which organizations are given the opportunity to respond is left up to the configuration of the Workflow Manager and is outside of the scope of this specification.

### 2.2.2.1 Triggers

- Request Referral COMPLETED

### 2.2.2.2 Actions

#### *2.2.2.2.1 Receivers are available and No Bidding is Needed*

The Workflow Manager may determine that this Collaboration Circle does not use bidding for referrals.

The Workflow Manager:

1. Publishes any supporting referenced documents that have not already been shared in the HIE Infrastructure.
  - a. Ensures that the **Referral Request Document** is published.
2. Creates a new Dispatch Referral Task.
  - a. The status of the task is set to COMPLETED.
  - b. The task is assigned to the Workflow Manager itself.
  - c. Adds a reference to the **Referral Request Document** to the **Output Documents** for the task.
3. Publishes any supporting referenced documents that have not already been shared in the HIE Infrastructure.
  - a. Ensures that the **Referral Request Document** is published.
  - b. Ensures that the **Relevant Clinical documents** are published.
4. Creates a new Respond to a Referral Request Task.

A Respond to a Referral Request is created for each Referral/Transfer Receiver actor selected by the Workflow Manager to respond to this request.

- a. The status of the task is set to READY.
- b. The task is assigned to the Referral/Transfer Receiver.

- c. Adds a reference to the **Referral Request Document** to the **Input Documents** for the task.
- d. Adds a reference to the **Relevant Clinical documents** to the **Input Documents** for the task.
- e. Adds a reference to the **Referral Request Document** to the **Output Documents** for the task.

#### ***2.2.2.2.2 Receivers are available and Bidding is Needed***

The Workflow Manager may determine that this Collaboration Circle requires referrals to be bid upon.

Note: Members of a Collaboration Circle that do not support bidding should respond to a Bid on Referral Request with an indication that they cannot accept transfers that require bidding.

The Workflow Manager:

1. Publishes any supporting referenced documents that have not already been shared in the HIE Infrastructure.
  - a. Ensures that the **Referral Request Document** is published.
2. Creates a new Dispatch Referral Task.
  - a. The status of the task is set to COMPLETED.
  - b. The task is assigned to the Workflow Manager itself.
  - c. Adds a reference to the **Referral Request Document** to the **Output Documents** for the task.
3. Publishes any supporting referenced documents that have not already been shared in the HIE Infrastructure.
  - a. Ensures that the **Referral Request Document** is published.
  - b. Ensures that the **Relevant Clinical documents** are published.
4. Creates a new Bid on a Referral Request Task.

A Bid on a Referral Request is created for each Referral/Transfer Receiver actor selected by the Workflow Manager to respond to this request.

- a. The status of the task is set to READY.
- b. The task is assigned to the Referral/Transfer Receiver.
- c. Adds a reference to the **Referral Request Document** to the **Input Documents** for the task.
- d. Adds a reference to the **Relevant Clinical documents** to the **Input Documents** for the task.
- e. Adds a reference to the **Referral Request Document** to the **Output Documents** for the task.

#### ***2.2.2.2.3 Reassigning to another Circle***

In some cases, the Workflow Manager may need to reassign the request to another Collaboration Circle. To do so, it simply sets the Workflow Manager owning the Dispatch Referral task to the Workflow Manager responsible for managing that Collaborator Circle.

The Workflow Manager:

1. Reassign the Dispatch Referral Task to another Workflow Manager.

#### ***2.2.2.2.4 Cannot Dispatch because no Receivers are available***

There may be cases where the Referral/Transfer Receivers of a Collaboration Circle cannot respond (e.g., due to natural disaster or other exceptional cases). In these cases, the Workflow Manager may simply fail the request.

The Workflow Manager:

1. Publishes any supporting referenced documents that have not already been shared in the HIE Infrastructure.
  - a. Ensures that the **Referral Request Document** is published.
2. Creates a new Dispatch Referral Task.
  - a. The status of the task is set to FAILURE.
  - b. The task is assigned to the Workflow Manager itself.
  - c. Adds a reference to the **Referral Request Document** to the **Output Documents** for the task.
  - d. The Workflow is marked as CLOSED and has Failed
3. Publishes any supporting referenced documents that have not already been shared in the HIE Infrastructure.
  - a. Ensures that the **Relevant Clinical documents** are published.
  - b. Ensures that the **Referral Request Document** is published.
4. Transitions the Request Referral Task to FAILURE.
  - a. Adds a reference to the **Relevant Clinical documents** to the **Input Documents** for the task.
  - b. Adds a reference to the **Referral Request Document** to the **Output Documents** for the task.
  - c. The Workflow is marked as CLOSED and has Failed

### **2.2.3 Evaluate Bid**

The Referral/Transfer Receiver must determine whether or not to bid on a referral or transfer when it has been assigned through the Bid on Referral Task or Bid on Transfer Task. If it determines that a bid will be made, then the workflow would transition to the Respond to Referral Task or Respond to Transfer Task, otherwise the workflow fails.

#### **2.2.3.1 Triggers**

- Bid on a Referral Request READY

#### **2.2.3.2 Actions**

##### ***2.2.3.2.1 Bidding not acceptable***

If bids are not processed by this receiver, the task can be failed.

The Referral/Transfer Receiver:

1. Transitions the Bid on a Referral Request Task to FAILURE.

### **2.2.3.2.2 Bidding acceptable**

The Referral/Transfer Receiver:

1. Publishes any supporting referenced documents that have not already been shared in the HIE Infrastructure.
  - a. Ensures that the **Referral Request Document** is published.
  - b. Ensures that the **Relevant Clinical documents** are published.
2. Creates a new Respond to a Transfer Request Task.

The Respond to a Referral Request task is created to signal that the Referral/Transfer Receiver is ready to respond to this request.

- a. The status of the task is set to READY.
  - b. The task is assigned to the Referral/Transfer Receiver itself.
  - c. Adds a reference to the **Referral Request Document** to the **Input Documents** for the task.
  - d. Adds a reference to the **Relevant Clinical documents** to the **Input Documents** for the task.
3. Transitions the Bid on a Referral Request Task to COMPLETED.
  - a. If bids are processed by this receiver, the task is completed and a response can be generated.

## **2.2.4 Evaluate Referral**

The Referral/Transfer Receiver must evaluate a referral when it has been assigned through the Respond to Referral Task, or when more information about it has been provided. It processes the Referral and responds in one of three ways as described in the sections below.

### **2.2.4.1 Triggers**

- Respond to a Referral Request READY
- Request Information COMPLETED

### **2.2.4.2 Actions**

#### **2.2.4.2.1 More Information is Needed**

If, during the processing of the request, the Referral/Transfer Receiver Actor determines that more information is needed (e.g., patient status information, lab results, etc.), it can be requested.

The Referral/Transfer Receiver:

1. Publishes any supporting referenced documents that have not already been shared in the HIE Infrastructure.
  - a. Ensures that the **Information Request Document** is published.
2. Creates a new Request Information Task.
  - a. The status of the task is set to READY.

- b. The task is assigned to the Referral Requester.
- c. Adds a reference to the **Information Request Document** to the **Input Documents** for the task.

#### ***2.2.4.2.2 No Need for More Information and CAN handle the referral***

If the Referral can be accepted, the Receiver should provide details about resources and services available in the response document.

The Referral/Transfer Receiver:

1. Publishes any supporting referenced documents that have not already been shared in the HIE Infrastructure.
  - a. Ensures that the **Referral Request Document** is published.
  - b. Ensures that the **Relevant Clinical documents** are published.
2. Transitions the Respond to a Referral Request Task to COMPLETED.
  - a. Adds a reference to the **Referral Request Document** to the **Input Documents** for the task.
  - b. Adds a reference to the **Relevant Clinical documents** to the **Input Documents** for the task.
  - c. Adds a reference to the **Referral/Transfer Response Document** to the **Output Documents** for the task.

#### ***2.2.4.2.3 No Need for More Information and CANNOT handle the referral***

If the Referral cannot be accepted, the receiver should describe the reason why the transfer cannot be accepted in the Referral/Transfer Response Document (e.g., lack of resources).

The Referral/Transfer Receiver:

1. Publishes any supporting referenced documents that have not already been shared in the HIE Infrastructure.
  - a. Ensures that the **Referral Request Document** is published.
  - b. Ensures that the **Relevant Clinical documents** are published.
  - c. Ensures that the **Referral/Transfer Response Document** is published.
2. Transitions the Respond to a Referral Request Task to FAILURE.
  - a. Adds a reference to the **Referral Request Document** to the **Input Documents** for the task.
  - b. Adds a reference to the **Relevant Clinical documents** to the **Input Documents** for the task.
  - c. Adds a reference to the **Referral/Transfer Response Document** to the **Output Documents** for the task.

#### ***2.2.4.2.4 Timeout occurs waiting for more information***

If the Referral Requester does not respond to a request for more information in a timely fashion, the receiver should indicate that the referral cannot be accepted due to a lack of response to the request for more information.

If the Referral Requester does not respond to a request for more information in a timely fashion, the receiver should indicate that the referral cannot be accepted due to a lack of response to the request for more information.

The Referral/Transfer Receiver:

1. Publishes any supporting referenced documents that have not already been shared in the HIE Infrastructure.
  - a. Ensures that the **Referral/Transfer Response Document** is published.
2. Transitions the Request Referral Task to FAILURE.
  - a. Adds a reference to the **Referral/Transfer Response Document** to the **Output Documents** for the task.
  - b. The Workflow is marked as CLOSED and has Failed

#### ***2.2.4.2.5 Referral is Cancelled***

If the Referral Requester cancels the request, the referral has failed.

The Referral/Transfer Receiver:

1. Publishes any supporting referenced documents that have not already been shared in the HIE Infrastructure.
  - a. Ensures that the Referral/Transfer Response Document is published.
2. Transitions the Request Referral Task to FAILURE.
  - a. Adds a reference to the Referral/Transfer Response Document to the Output Documents for the task.
  - b. The Workflow is marked as CLOSED and has Failed

### **2.2.5 Information Requested**

A Request Information Task is created by the Referral/Transfer Receiver Actor to request more information and the Requester is assigned to this task. The Referral Requester will provide the requested information as an Output Document on the task and mark the task as being COMPLETED. The Workflow Manager will then notify the creator of the Request Information Task that it is finished, allowing the Referral/Transfer Receiver to determine how it should handle the Referral or Transfer request.

#### **2.2.5.1 Triggers**

- Request Information READY

### 2.2.5.2 Actions

The Referral Requester:

1. Publishes any supporting referenced documents that have not already been shared in the HIE Infrastructure.
  - a. Ensures that the **Information Request Document** is published.
  - b. Ensures that the **Information Response Document AND/OR Relevant Clinical Documents** are published.
2. Transitions the Request Information Task to COMPLETED.
  - a. Adds a reference to the **Information Request Document** to the **Input Documents** for the task.
  - b. Adds a reference to the **Information Response Document AND/OR Relevant Clinical Documents** to the **Output Documents** for the task.

### 2.2.6 Process Referral Response

The Workflow Manager evaluates responses to determine whether it has received sufficient responses to process the referral. If it is able to make a determination about assignment it creates an assign referral task to indicate that the referral has been assigned to an organization. A Referral/Transfer Response Document will be attached as an Output Document. This Referral/Transfer Response Document may be one of the Referral/Transfer Response Documents provided by a Referral/Transfer Receiver, or it may be constructed by the Workflow Manager (e.g., in cases where it has escalated the request to make a decision). How the Workflow Manager makes a determination of which response to select is left up to the configuration of the Workflow Manager. If no organization accepts the referral, the Workflow Manager may still make an assignment. The rules governing how a Workflow Manager makes decisions is outside of the scope of this specification. If for some reason the Workflow Manager is not able to make an assignment decision, then it will mark the Assign Referral Task as being FAILED and notify the original Referral Requester. All Referral/Transfer Receivers that were asked to respond to the Referral Request must be notified of the results of an assignment so that they can update any resources reservations that may have been made in response to the request, regardless of whether they were the selected receiver.

#### 2.2.6.1 Triggers

- Respond to a Referral Request COMPLETED
- Respond to a Referral Request FAILURE
- Respond to a Referral Request FAILURE

#### 2.2.6.2 Actions

##### *2.2.6.2.1 An Acceptable Response has been Received*

The Workflow Manager will determine what makes for an acceptable response. Once an acceptable response has been received and the Referral organization selected, All

Referral/Transfer Receivers are notified so that any resource reservations can be appropriately updated.

The Workflow Manager:

1. Publishes any supporting referenced documents that have not already been shared in the HIE Infrastructure.
  - a. Ensures that the **Referral/Transfer Response Document** is published.
2. Creates a new Perform Referral Task.
  - a. The status of the task is set to CREATED.
  - b. The task is assigned to the Referral/Transfer Receiver.
  - c. Adds a reference to the **Referral/Transfer Response Document** to the **Output Documents** for the task.

#### ***2.2.6.2.2 Responses are still Pending***

When no acceptable response has yet been received, but more responses are expected, the Workflow Manager simply waits for another response or for this task to time out.

#### ***2.2.6.2.3 No acceptable response is Pending and can resolve through escalation***

When no acceptable responses have been received and no more are expected, the Workflow Manager may use escalation to make an assignment. All Referral/Transfer Receiver actors are notified because they may have resources whose reservations need to be updated.

The Workflow Manager:

1. Publishes any supporting referenced documents that have not already been shared in the HIE Infrastructure.
  - a. Ensures that the **Referral/Transfer Response Document** is published.
2. Creates a new Perform Referral Task.
  - a. The status of the task is set to CREATED.
  - b. The task is assigned to the Referral/Transfer Receiver.
  - c. Adds a reference to the **Referral/Transfer Response Document** to the **Output Documents** for the task.

#### ***2.2.6.2.4 No acceptable response is Pending and cannot resolve through escalation***

If escalation is not possible, then the Workflow Manager should fail the workflow. All Referral/Transfer Receiver actors are notified because they may have resources whose reservations need to be updated.

The Workflow Manager:

1. Publishes any supporting referenced documents that have not already been shared in the HIE Infrastructure.



- a. Ensures that the **Referral/Transfer Response Document** is published.
2. Creates a new Perform Referral Task.
  - a. The status of the task is set to FAILURE.
  - b. The task is assigned to the Referral/Transfer Receiver.
  - c. Adds a reference to the **Referral/Transfer Response Document** to the **Output Documents** for the task.
  - d. The Workflow is marked as CLOSED and has Failed
3. Publishes any supporting referenced documents that have not already been shared in the HIE Infrastructure.
  - a. Ensures that the **Relevant Clinical documents** are published.
  - b. Ensures that the **Referral/Transfer Request Document** is published.
4. Transitions the Request Referral Task to FAILURE.
  - a. Adds a reference to the **Relevant Clinical documents** to the **Input Documents** for the task.
  - b. Adds a reference to the **Referral/Transfer Request Document** to the **Output Documents** for the task.
  - c. The Workflow is marked as CLOSED and has Failed

### **2.2.7 Timeout on Referral Response**

When no acceptable responses have been received within an adequate time period, the Workflow Manager must make a determination how to handle the request. It may escalate the referral request to ensure that a response is provided, or it may mark the task as failed.

All Referral/Transfer Receivers must be notified of the failure so that they can update any resources reservations that may have been made in response to the request.

#### **2.2.7.1 Triggers**

- Respond to Referral Request
- Bid on a Referral Request Timeout

#### **2.2.7.2 Actions**

##### ***2.2.7.2.1 Can resolve through escalation***

When insufficient responses have been received but the Workflow Manager is able to resolve the referral through escalation, it will create the Perform Referral task and make an assignment. All Referral/Transfer Receiver actors are notified because they may have resources whose reservations need to be updated.

The Workflow Manager:

1. Publishes any supporting referenced documents that have not already been shared in the HIE Infrastructure.
  - a. Ensures that the **Referral/Transfer Response Document** is published.
2. Creates a new Perform Referral Task.

- a. The status of the task is set to CREATED.
- b. The task is assigned to the Referral/Transfer Receiver.
- c. Adds a reference to the **Referral/Transfer Response Document** to the **Output Documents** for the task.

#### ***2.2.7.2.2 Cannot resolve through escalation***

When insufficient responses have been received and the Workflow Manager is unable to resolve the referral through escalation, it will fail this workflow. All Referral/Transfer Receiver actors are notified of the failure because they may have resources whose reservations need to be updated.

The Workflow Manager:

1. Publishes any supporting referenced documents that have not already been shared in the HIE Infrastructure.
  - a. Ensures that the **Referral/Transfer Response Document** is published.
2. Creates a new Perform Referral Task.
  - a. The status of the task is set to FAILURE.
  - b. The task is assigned to the Referral/Transfer Receiver.
  - c. Adds a reference to the **Referral/Transfer Response Document** to the **Output Documents** for the task.
  - d. The Workflow is marked as CLOSED and has Failed
3. Publishes any supporting referenced documents that have not already been shared in the HIE Infrastructure.
  - a. Ensures that the **Relevant Clinical documents** are published.
  - b. Ensures that the **Referral Request Document** is published.
4. Transitions the Request Referral Task to FAILURE.
  - a. Adds a reference to the **Relevant Clinical documents** to the **Input Documents** for the task.
  - b. Adds a reference to the **Referral Request Document** to the **Output Documents** for the task.
  - c. The Workflow is marked as CLOSED and has Failed

### **2.2.8 Make Appointment**

The patient may make an appointment for the referral. If an appointment is made, the Referral/Transfer Receiver shall Transition the Perform Referral Task to the READY state and attach the Appointment as an Input of that task.

#### **2.2.8.1 Triggers**

- Perform Referral CREATED

### 2.2.8.2 Actions

The Referral/Transfer Receiver:

1. Publishes any supporting referenced documents that have not already been shared in the HIE Infrastructure.
  - a. Ensures that the **Appointment Document** is published.
  - b. Ensures that the **Referral/Transfer Response Document** is published.
  - c. Ensures that the **Referral Request Document** is published.
2. Transitions the Perform Referral Task to READY.
  - a. Adds a reference to the **Appointment Document** to the **Input Documents** for the task.
  - b. Adds a reference to the **Referral/Transfer Response Document** to the **Input Documents** for the task.
  - c. Adds a reference to the **Referral Request Document** to the **Output Documents** for the task.

### 2.2.9 Pending Patient Arrival

At this stage the referral has been assigned and potentially scheduled with an appointment. The Referral/Transfer Receiver Actor will report on the status of the referral based upon patient arrival.

#### 2.2.9.1 Triggers

- Perform Referral READY

#### 2.2.9.2 Actions

##### *2.2.9.2.1 The Referral occurs within a reasonable time frame*

When the patient arrives the Perform Referral task is updated.

The Referral/Transfer Receiver:

1. Publishes any supporting referenced documents that have not already been shared in the HIE Infrastructure.
  - a. Ensures that the **Referral/Transfer Response Document** is published.
  - b. Ensures that the **Referral Request Document** is published.
2. Transitions the Perform Referral Task to IN\_PROGRESS.
  - a. Adds a reference to the **Referral/Transfer Response Document** to the **Input Documents** for the task.
  - b. Adds a reference to the **Referral Request Document** to the **Output Documents** for the task.

##### *2.2.9.2.2 The Patient arrives at another organization for the referral rather than the one selected*

This is an exceptional case. The Referral/Transfer Receiver associated with organization that the patient arrives at must take ownership of the Perform Referral Task and process it as if it had been the assigned receiver.

The Referral/Transfer Receiver:

1. Publishes any supporting referenced documents that have not already been shared in the HIE Infrastructure.
  - a. Ensures that the **Referral/Transfer Response Document** is published.
  - b. Ensures that the **ReferralRequest Document** is published.
2. Transitions the Perform Referral Task to IN\_PROGRESS.
  - a. Adds a reference to the **Referral/Transfer Response Document** to the **Input Documents** for the task.
  - b. Adds a reference to the **Referral Request Document** to the **Output Documents** for the task.

#### ***2.2.9.2.3 The Referral does not occur within a reasonable time frame and another organization has not already started the referral***

If the patient does not arrive in a timely fashion the Perform Referral task will be transitioned to the FAILURE state.

The Referral/Transfer Receiver:

1. Publishes any supporting referenced documents that have not already been shared in the HIE Infrastructure.
  - a. Ensures that the **Referral/Transfer Response Document** is published.
  - b. Ensures that the **Referral Request Document** is published.
2. Transitions the Perform Referral Task to FAILURE.
  - a. Adds a reference to the **Referral/Transfer Response Document** to the **Input Documents** for the task.
  - b. Adds a reference to the **Referral Request Document** to the **Output Documents** for the task.
  - c. The Workflow is marked as CLOSED and has Failed

### **2.2.10 Referral Services Initiated**

At this stage the referral services have started. The Referral/Transfer Receiver Actor will report on the status of the completion of those services.

#### **2.2.10.1 Triggers**

- Perform Referral IN\_PROGRESS

#### **2.2.10.2 Actions**

##### ***2.2.10.2.1 The Referral Completes Successfully***

When the services are complete the Perform Referral task will be transitioned to the COMPLETED state, and the results of the services will be recorded as one or more Output Documents on the Perform Referral Task.

The Referral/Transfer Receiver:

1. Publishes any supporting referenced documents that have not already been shared in the HIE Infrastructure.
  - a. Ensures that the **Referral/Transfer Response Document** is published.
  - b. Ensures that the **Referral Result Document** is published.
2. Transitions the Perform Referral Task to COMPLETED.
  - a. Adds a reference to the **Referral/Transfer Response Document** to the **Input Documents** for the task.
  - b. Adds a reference to the **Referral Result Document** to the **Output Documents** for the task.
  - c. The Workflow is marked as CLOSED and has Succeeded

#### ***2.2.10.2.2 The Referral did not complete Successfully***

If the services could not be completed the Perform Referral task will be transitioned to the FAILURE state, and any partial results will be recorded as one or more Output Documents on the Perform Referral Task.

The Referral/Transfer Receiver:

1. Publishes any supporting referenced documents that have not already been shared in the HIE Infrastructure.
  - a. Ensures that the **Referral/Transfer Response Document** is published.
  - b. Ensures that the **Referral Result Document** is published.
2. Transitions the Perform Referral Task to FAILURE.
  - a. Adds a reference to the **Referral/Transfer Response Document** to the **Input Documents** for the task.
  - b. Adds a reference to the **Referral Result Document** to the **Output Documents** for the task.
  - c. The Workflow is marked as CLOSED and has Failed

## **2.3 DIRECT TRANSFER**

In the Direct Transfer Workflow a physician may request a transfer from a specific hospital. That hospital responds with their ability to accept the transfer. If they are able to accept the patient the transfer is initiated. No Workflow Manager is engaged in this process.

*TABLE 2.3-1 DIRECT TRANSFER WORKFLOW ACTIVITIES*

STEP	ACTOR	NEXT STEP
1. Initiate Transfer	Transfer Requester	Go to Evaluate Transfer.
2. Evaluate Transfer	Referral/Transfer Receiver	If more information is needed go to Information Requested. If no need for more information and can handle the transfer go to Process Direct Transfer Response.

STEP	ACTOR	NEXT STEP
		<p>If no need for more information and cannot handle the transfer this workflow is completed and has failed.</p> <p>If timeout occurs waiting for more information this workflow is completed and has failed.</p> <p>If the transfer is cancelled this workflow is completed and has failed.</p>
3. Information Requested	Transfer Requester	Go to Evaluate Transfer.
4. Process Direct Transfer Response	Transfer Requester	<p>If acceptable response is received go to Pending Transfer.</p> <p>If no acceptable response has been received this workflow is completed and has failed.</p>
5. Pending Transfer	Transfer Requester	<p>If patient transport is initiated go to Patient Admission.</p> <p>If patient transport is not initiated this workflow is completed and has failed.</p>
6. Patient Admission	Referral/Transfer Receiver	<p>If the patient transport is completed within reasonable time frame this workflow is completed and has succeeded.</p> <p>If the patient's admission is completed at a different hospital this workflow is completed and has succeeded.</p> <p>If the patient's admission is not completed at a different hospital and is not completed within reasonable time frame this workflow is completed and has failed.</p>

### 2.3.1 Initiate Transfer

In this step, the Transfer Requester Actor initiates a transfer by creating the Transfer Request task, providing references to relevant Clinical Documents (e.g., Encounter Summary, Discharge Summary, Lab Result Report, Imaging Report, et cetera) and the Transfer Request Document.

#### 2.3.1.1 Triggers

- The Patient Needs a Transfer

#### 2.3.1.2 Actions

The Transfer Requester:

1. Publishes any supporting referenced documents that have not already been shared in the HIE Infrastructure.
  - a. Ensures that the **Relevant Clinical documents** is published.
  - b. Ensures that the **Transfer Request Document** is published.
2. Creates a new Request Transfer Task.
  - a. The status of the task is set to **COMPLETED**.
  - b. The task is assigned to the Transfer Requester itself.
  - c. Adds a reference to the **Relevant Clinical documents** to the **Input Documents** for the task.
  - d. Adds a reference to the **Transfer Request Document** to the **Output Documents** for the task.

3. Publishes any supporting referenced documents that have not already been shared in the HIE Infrastructure.
  - a. Ensures that the **Transfer Request Document** is published.
  - b. Ensures that the **Relevant Clinical documents** is published.
4. Creates a new Respond to a Transfer Request Task.
  - a. The status of the task is set to READY.
  - b. The task is assigned to the Referral/Transfer Receiver.
  - c. Adds a reference to the **Transfer Request Document** to the **Input Documents** for the task.
  - d. Adds a reference to the **Relevant Clinical documents** to the **Input Documents** for the task.

### **2.3.2 Evaluate Transfer**

The Referral/Transfer Receiver must evaluate a transfer when it has been assigned through the Respond to Transfer Task, or when more information about it has been provided. It processes the Transfer and responds in one of three ways:

#### **2.3.2.1 Triggers**

- Respond to a Transfer Request READY
- Request Information COMPLETED

#### **2.3.2.2 Actions**

##### ***2.3.2.2.1 More Information is Needed***

If, during the processing of the request, the Referral/Transfer Receiver Actor determines that more information is needed (e.g., patient status information, lab results, etc.), it can be requested.

The Referral/Transfer Receiver:

1. Publishes any supporting referenced documents that have not already been shared in the HIE Infrastructure.
  - a. Ensures that the **Information Request Document** is published.
2. Creates a new Request Information Task.
  - a. The status of the task is set to READY.
  - b. The task is assigned to the Transfer Requester.
  - c. Adds a reference to the **Information Request Document** to the **Input Documents** for the task.

##### ***2.3.2.2.2 No Need for More Information and CAN handle the Transfer***

If the Transfer can be accepted, the Receiver should provide details about resources and services available in the response document.

The Referral/Transfer Receiver:

1. Publishes any supporting referenced documents that have not already been shared in the HIE Infrastructure.
  - a. Ensures that the **Referral/Transfer Response Document** is published.
2. Transitions the Respond to a Transfer Request Task to COMPLETED.
  - a. Adds a reference to the **Referral/Transfer Response Document** to the **Output Documents** for the task.

#### ***2.3.2.2.3 No Need for More Information and CANNOT handle the Transfer***

If the Transfer cannot be accepted, the receiver should describe the reason why the transfer cannot be accepted in the Referral/Transfer Response Document (e.g., lack of resources).

The Referral/Transfer Receiver:

1. Publishes any supporting referenced documents that have not already been shared in the HIE Infrastructure.
  - a. Ensures that the **Referral/Transfer Response Document** is published.
2. Transitions the Respond to a Transfer Request Task to FAILURE.
  - a. Adds a reference to the **Referral/Transfer Response Document** to the **Output Documents** for the task.
3. Publishes any supporting referenced documents that have not already been shared in the HIE Infrastructure.
  - a. Ensures that the **Referral/Transfer Response Document** is published.
4. Transitions the Request Transfer Task to FAILURE.
  - a. Adds a reference to the **Referral/Transfer Response Document** to the **Output Documents** for the task.
  - b. The Workflow is marked as CLOSED and has Failed

#### ***2.3.2.2.4 Timeout occurs waiting for more information***

If the Transfer Requester does not respond to a request for more information in a timely fashion, the receiver should indicate that the transfer cannot be accepted due to a lack of response to the request for more information.

The Referral/Transfer Receiver:

1. Publishes any supporting referenced documents that have not already been shared in the HIE Infrastructure.
  - a. Ensures that the **Referral/Transfer Response Document** is published.
2. Transitions the Request Transfer Task to FAILURE.
  - a. Adds a reference to the **Referral/Transfer Response Document** to the **Output Documents** for the task.
  - b. The Workflow is marked as CLOSED and has Failed



### **2.3.2.2.5 Transfer is Cancelled**

If the Transfer Requester cancels the request, the transfer has failed.

The Referral/Transfer Receiver:

1. Publishes any supporting referenced documents that have not already been shared in the HIE Infrastructure.
  - a. Ensures that the Referral/Transfer Response Document is published.
2. Transitions the Request Transfer Task to FAILURE.
  - a. Adds a reference to the Referral/Transfer Response Document to the Output Documents for the task.
  - b. The Workflow is marked as CLOSED and has Failed

### **2.3.3 Information Requested**

A Request Information Task is created by the Referral/Transfer Receiver Actor to request more information and the Requester is assigned to this task. The Referral Requester will provide the requested information as an Output Document on the task and mark the task as being COMPLETED. The Workflow Manager will then notify the creator of the Request Information Task that it is finished, allowing the Referral/Transfer Receiver to determine how it should handle the Referral or Transfer request.

#### **2.3.3.1 Triggers**

- Request Information READY

#### **2.3.3.2 Actions**

The Transfer Requester:

1. Publishes any supporting referenced documents that have not already been shared in the HIE Infrastructure.
  - a. Ensures that the **Information Response Document AND/OR Relevant Clinical Documents** is published.
2. Transitions the Request Information Task to COMPLETED.
  - a. Adds a reference to the **Information Response Document AND/OR Relevant Clinical Documents** to the **Output Documents** for the task.

### **2.3.4 Process Direct Transfer Response**

The Transfer Requester evaluates the response to determine whether the transfer can be completed.

### 2.3.4.1 Triggers

- Respond to a Transfer Request COMPLETED
- Timeout on Response

### 2.3.4.2 Actions

#### ***2.3.4.2.1 Acceptable Response is Received***

The Transfer Requester will determine what makes for an acceptable response.

The Transfer Requester:

1. Publishes any supporting referenced documents that have not already been shared in the HIE Infrastructure.
  - a. Ensures that the **Referral/Transfer Response Document** is published.
2. Creates a new Perform Transfer Task.
  - a. The status of the task is set to READY.
  - b. The task is assigned to the Referral/Transfer Receiver.
  - c. Adds a reference to the **Referral/Transfer Response Document** to the **Output Documents** for the task.

#### ***2.3.4.2.2 No acceptable response has been Received***

In the case where an acceptable response is not received (e.g., because the Direct Transfer receiver may not have available resources), this workflow fails. The Transfer Requester may initiate a new Transfer Attempt through a Collaboration Circle if desired.

The Transfer Requester:

1. Publishes any supporting referenced documents that have not already been shared in the HIE Infrastructure.
  - a. Ensures that the **Referral/Transfer Response Document** is published.
2. Transitions the Request Transfer Task to FAILURE.
  - a. Adds a reference to the **Referral/Transfer Response Document** to the **Output Documents** for the task.
  - b. The Workflow is marked as CLOSED and has Failed

### 2.3.5 Pending Transfer

The next stage is for the Transfer Requester to report on the status of the transport of the patient to the transfer location.

#### 2.3.5.1 Triggers

- Perform Transfer READY

## 2.3.5.2 Actions

### *2.3.5.2.1 Patient transport is initiated*

If transport has begun the Perform Transfer Task should be changed to the IN\_PROGRESS state.

The Transfer Requester:

1. Publishes any supporting referenced documents that have not already been shared in the HIE Infrastructure.
  - a. Ensures that the **Appointment Document** is published.
  - b. Ensures that the **Transfer Request Document** is published.
  - c. Ensures that the **Referral/Transfer Response Document** is published.
2. Transitions the Perform Transfer Task to IN\_PROGRESS.
  - a. Adds a reference to the **Appointment Document** to the **Input Documents** for the task.
  - b. Adds a reference to the **Transfer Request Document** to the **Input Documents** for the task.
  - c. Adds a reference to the **Referral/Transfer Response Document** to the **Output Documents** for the task.

### *2.3.5.2.2 Patient transport is not initiated*

If transport is canceled the Perform Transfer Task should be changed to the FAILURE state.

The Transfer Requester:

1. Publishes any supporting referenced documents that have not already been shared in the HIE Infrastructure.
  - a. Ensures that the **Referral/Transfer Response Document** is published.
2. Transitions the Perform Transfer Task to FAILURE.
  - a. Adds a reference to the **Referral/Transfer Response Document** to the **Output Documents** for the task.
  - b. The Workflow is marked as CLOSED and has Failed

## 2.3.6 Patient Admission

Once the patient is in transit, the Transfer/Referral Requester should report the status of the patient arrival.

### 2.3.6.1 Triggers

- Perform Transfer IN\_PROGRESS

### 2.3.6.2 Actions

#### *2.3.6.2.1 The Patient transport is completed within reasonable time frame*

When the patient arrives for the transfer the Perform Transfer Task should be changed to the COMPLETED state.

The Referral/Transfer Receiver:

1. Publishes any supporting referenced documents that have not already been shared in the HIE Infrastructure.
  - a. Ensures that the **Referral/Transfer Response Document** is published.
2. Transitions the Perform Transfer Task to COMPLETED.
  - a. Adds a reference to the **Referral/Transfer Response Document** to the **Input Documents** for the task.
  - b. The Workflow is marked as CLOSED and has Succeeded

#### ***2.3.6.2.2 The Patient's admission is completed at a different hospital***

This is an exceptional case. The Transfer/Referral Receiver actor associated with the admitting hospital may locate the transfer by query against workflows for the patient. It should reopen the workflow to indicate that the patient was admitted elsewhere before closing it again.

The Referral/Transfer Receiver:

1. Publishes any supporting referenced documents that have not already been shared in the HIE Infrastructure.
  - a. Ensures that the **Referral/Transfer Response Document** is published.
2. Transitions the Perform Transfer Task to COMPLETED.
  - a. Adds a reference to the **Referral/Transfer Response Document** to the **Input Documents** for the task.
  - b. The Workflow is marked as CLOSED and has Succeeded

#### ***2.3.6.2.3 The Patient's admission is not completed at a different hospital and is not completed within reasonable time frame***

The Referral/Transfer Receiver should first check to see if the patient was admitted elsewhere. This can be determined by checking the status of the workflow. If the workflow is not CLOSED, it should indicate that the admission did not complete. Otherwise, the workflow must have been closed by another actor, indicating either a failed transfer, or a successful transfer somewhere else.

The Referral/Transfer Receiver:

1. Publishes any supporting referenced documents that have not already been shared in the HIE Infrastructure.
  - a. Ensures that the **Referral/Transfer Response Document** is published.
2. Transitions the Perform Transfer Task to FAILURE.
  - a. Adds a reference to the **Referral/Transfer Response Document** to the **Input Documents** for the task.

b. The Workflow is marked as CLOSED and has Failed

## 2.4 DIRECT REFERRAL

In the Direct Referral Workflow a physician may request a referral to a specific hospital. That hospital responds with their ability to accept the referral. If they are able to accept the patient the referral is made. No Workflow Manager is involved in this process.

TABLE 2.4-1 DIRECT REFERRAL WORKFLOW ACTIVITIES

STEP	ACTOR	NEXT STEP
1. Initiate Referral	Referral Requester	Go to Evaluate Referral.
2. Evaluate Referral	Referral/Transfer Receiver	If more information is needed go to Information Requested. If no need for more information and can handle the referral go to Process Direct Referral Response. If no need for more information and cannot handle the referral this workflow is completed and has failed. If timeout occurs waiting for more information this workflow is completed and has failed. If the request is cancelled this workflow is completed and has failed.
3. Information Requested	Referral Requester	Go to Evaluate Referral.
4. Process Direct Referral Response	Referral Requester	If an acceptable response has been received go to Make Appointment. If no acceptable response has been received this workflow is completed and has failed.
5. Make Appointment	Referral/Transfer Receiver	Go to Pending Patient Arrival.
6. Pending Patient Arrival	Referral/Transfer Receiver	If the patient arrives for the referral within a reasonable time frame go to Referral Services Initiated. If the patient does not arrive for the referral within a reasonable time frame this workflow is completed and has failed.
7. Referral Services Initiated	Referral/Transfer Receiver	If referral completes successfully this workflow is completed and has succeeded. If referral does not complete successfully this workflow is completed and has failed.

### 2.4.1 Initiate Referral

In this step, the Referral Requester Actor initiates a referral by creating the Referral Request task, providing references to relevant Clinical Documents (e.g., Encounter Summary, Discharge Summary, Lab Result Report, Imaging Report, et cetera) and the Referral Request Document.

#### 2.4.1.1 Triggers

- The Patient Needs a Referral

### 2.4.1.2 Actions

The Referral Requester:

1. Publishes any supporting referenced documents that have not already been shared in the HIE Infrastructure.
  - a. Ensures that the **Relevant Clinical documents** are published.
  - b. Ensures that the **Referral Request Document** is published.
2. Creates a new Request Referral Task.
  - a. The status of the task is set to COMPLETED.
  - b. The task is assigned to the Referral Requester itself.
  - c. Adds a reference to the **Relevant Clinical documents** to the **Input Documents** for the task.
  - d. Adds a reference to the **Referral Request Document** to the **Output Documents** for the task.
3. Publishes any supporting referenced documents that have not already been shared in the HIE Infrastructure.
  - a. Ensures that the **Referral Request Document** is published.
  - b. Ensures that the **Relevant Clinical documents** are published.
4. Creates a new Respond to a Referral Request Task.
  - a. The status of the task is set to READY.
  - b. The task is assigned to the Referral/Transfer Receiver.
  - c. Adds a reference to the **Referral Request Document** to the **Input Documents** for the task.
  - d. Adds a reference to the **Relevant Clinical documents** to the **Input Documents** for the task.

### 2.4.2 Evaluate Referral

The Referral/Transfer Receiver must evaluate a referral when it has been assigned through the Respond to Referral Task, or when more information about it has been provided. It processes the Referral and responds in one of three ways as described in the sections below.

#### 2.4.2.1 Triggers

- Respond to a Referral Request READY
- Request Information COMPLETED

#### 2.4.2.2 Actions

##### *2.4.2.2.1 More Information is Needed*

If, during the processing of the request, the Referral/Transfer Receiver Actor determines that more information is needed (e.g., patient status information, lab results, etc.), it can be requested.

The Referral/Transfer Receiver:

1. Publishes any supporting referenced documents that have not already been shared in the HIE Infrastructure.
  - a. Ensures that the **Information Request Document** is published.

2. Creates a new Request Information Task.
  - a. The status of the task is set to READY.
  - b. The task is assigned to the Referral Requester.
  - c. Adds a reference to the **Information Request Document** to the **Input Documents** for the task.

#### ***2.4.2.2.2 No Need for More Information and CAN handle the referral***

If the Referral can be accepted, the Receiver should provide details about resources and services available in the response document.

The Referral/Transfer Receiver:

1. Publishes any supporting referenced documents that have not already been shared in the HIE Infrastructure.
  - a. Ensures that the **Referral/Transfer Response Document** is published.
2. Transitions the Respond to a Referral Request Task to COMPLETED.
  - a. Adds a reference to the **Referral/Transfer Response Document** to the **Output Documents** for the task.

#### ***2.4.2.2.3 No Need for More Information and CANNOT handle the referral***

If the Referral cannot be accepted, the receiver should describe the reason why the transfer cannot be accepted in the Referral/Transfer Response Document (e.g., lack of resources).

The Referral/Transfer Receiver:

1. Publishes any supporting referenced documents that have not already been shared in the HIE Infrastructure.
  - a. Ensures that the **Referral/Transfer Response Document** is published.
2. Transitions the Respond to a Referral Request Task to FAILURE.
  - a. Adds a reference to the **Referral/Transfer Response Document** to the **Output Documents** for the task.
3. Publishes any supporting referenced documents that have not already been shared in the HIE Infrastructure.
  - a. Ensures that the **Referral Request Document** is published.
4. Transitions the Request Referral Task to FAILURE.
  - a. Adds a reference to the **Referral Request Document** to the **Output Documents** for the task.
  - b. The Workflow is marked as CLOSED and has Failed

#### ***2.4.2.2.4 Timeout occurs waiting for more information***

If the Referral Requester does not respond to a request for more information in a timely fashion, the receiver should indicate that the referral cannot be accepted due to a lack of response to the request for more information.

The Referral/Transfer Receiver:

1. Publishes any supporting referenced documents that have not already been shared in the HIE Infrastructure.
  - a. Ensures that the **Referral/Transfer Response Document** is published.
2. Transitions the Request Referral Task to FAILURE.
  - a. Adds a reference to the **Referral/Transfer Response Document** to the **Output Documents** for the task.
  - b. The Workflow is marked as CLOSED and has Failed

#### ***2.4.2.2.5 Referral is Cancelled***

If the Referral Requester cancels the request, the referral has failed.

The Referral/Transfer Receiver:

1. Publishes any supporting referenced documents that have not already been shared in the HIE Infrastructure.
  - a. Ensures that the Referral/Transfer Response Document is published.
2. Transitions the Request Referral Task to FAILURE.
  - a. Adds a reference to the Referral/Transfer Response Document to the Output Documents for the task.
  - b. The Workflow is marked as CLOSED and has Failed

### **2.4.3 Information Requested**

A Request Information Task is created by the Referral/Transfer Receiver Actor to request more information and the Requester is assigned to this task. The Referral Requester will provide the requested information as an Output Document on the task and mark the task as being COMPLETED. The Workflow Manager will then notify the creator of the Request Information Task that it is finished, allowing the Referral/Transfer Receiver to determine how it should handle the Referral or Transfer request.

#### **2.4.3.1 Triggers**

- Request Information READY

#### **2.4.3.2 Actions**

The Referral Requester:

1. Publishes any supporting referenced documents that have not already been shared in the HIE Infrastructure.
  - a. Ensures that the **Information Response Document AND/OR Relevant Clinical Documents** are published.
2. Transitions the Request Information Task to COMPLETED.



- a. Adds a reference to the **Information Response Document AND/OR Relevant Clinical Documents** to the **Output Documents** for the task.

## **2.4.4 Process Direct Referral Response**

The Referral Requester evaluates the response to determine whether the transfer can be completed.

### **2.4.4.1 Triggers**

- Respond to a Referral Request COMPLETED
- Timeout on Response

### **2.4.4.2 Actions**

#### ***2.4.4.2.1 An Acceptable Response has been Received***

The Referral Requester will determine what makes for an acceptable response.

The Referral Requester:

1. Publishes any supporting referenced documents that have not already been shared in the HIE Infrastructure.
  - a. Ensures that the **Referral Request Document** is published.
  - b. Ensures that the **Referral/Transfer Response Document** is published.
2. Creates a new Perform Referral Task.
  - a. The status of the task is set to **CREATED**.
  - b. The task is assigned to the Referral/Transfer Receiver.
  - c. Adds a reference to the **Referral Request Document** to the **Input Documents** for the task.
  - d. Adds a reference to the **Referral/Transfer Response Document** to the **Input Documents** for the task.

#### ***2.4.4.2.2 No acceptable response has been received***

In the case where an acceptable response is not received (e.g., because the Direct Referral receiver may not have available resources), this workflow fails. The Referral Requester may initiate a new Referral Attempt through a Collaboration Circle if desired.

The Referral Requester:

1. Transitions the Request Referral Task to **FAILURE**.
  - a. The Workflow is marked as **CLOSED** and has Failed

## 2.4.5 Make Appointment

The patient may make an appointment for the referral. If an appointment is made, the Referral/Transfer Receiver shall Transition the Perform Referral Task to the READY state and attach the Appointment as an Input of that task.

### 2.4.5.1 Triggers

- Perform Referral CREATED

### 2.4.5.2 Actions

The Referral/Transfer Receiver:

1. Publishes any supporting referenced documents that have not already been shared in the HIE Infrastructure.
  - a. Ensures that the **Appointment Document** is published.
2. Transitions the Perform Referral Task to READY.
  - a. Adds a reference to the **Appointment Document** to the **Input Documents** for the task.

## 2.4.6 Pending Patient Arrival

At this stage the referral has been assigned and potentially scheduled with an appointment. The Referral/Transfer Receiver Actor will report on the status of the referral based upon patient arrival.

### 2.4.6.1 Triggers

- Perform Referral READY

### 2.4.6.2 Actions

#### ***2.4.6.2.1 The Patient arrives for the referral within a reasonable time frame***

The Referral/Transfer Receiver:

1. Publishes any supporting referenced documents that have not already been shared in the HIE Infrastructure.
  - a. Ensures that the **Referral/Transfer Response Document** is published.
2. Transitions the Perform Referral Task to IN\_PROGRESS.
  - a. Adds a reference to the **Referral/Transfer Response Document** to the **Input Documents** for the task.

#### ***2.4.6.2.2 The Patient does not arrive for the Referral within a reasonable time frame***

The Referral/Transfer Receiver:

1. Publishes any supporting referenced documents that have not already been shared in the HIE Infrastructure.
  - a. Ensures that the **Referral/Transfer Response Document** is published.
2. Transitions the Perform Referral Task to FAILURE.
  - a. Adds a reference to the **Referral/Transfer Response Document** to the **Input Documents** for the task.
  - b. The Workflow is marked as CLOSED and has Failed

## **2.4.7 Referral Services Initiated**

At this stage the referral services have started. The Referral/Transfer Receiver Actor will report on the status of the completion of those services.

### **2.4.7.1 Triggers**

- Perform Referral IN\_PROGRESS

### **2.4.7.2 Actions**

#### ***2.4.7.2.1 Referral Completes Successfully***

When the services are complete the Perform Referral task will be transitioned to the COMPLETED state, and the results of the services will be recorded as one or more Output Documents on the Perform Referral Task.

The Referral/Transfer Receiver:

1. Publishes any supporting referenced documents that have not already been shared in the HIE Infrastructure.
  - a. Ensures that the **Referral Result Document** is published.
2. Transitions the Perform Referral Task to COMPLETED.
  - a. Adds a reference to the **Referral Result Document** to the **Output Documents** for the task.
  - b. The Workflow is marked as CLOSED and has Succeeded

#### ***2.4.7.2.2 Referral Does not Complete Successfully***

If the services could not be completed the Perform Referral task will be transitioned to the FAILURE state, and any partial results will be recorded as one or more Output Documents on the Perform Referral Task.

The Referral/Transfer Receiver:

1. Publishes any supporting referenced documents that have not already been shared in the HIE Infrastructure.

- a. Ensures that the **Referral Result Document** is published.
2. Transitions the Perform Referral Task to FAILURE.
  - a. Adds a reference to the **Referral Result Document** to the **Output Documents** for the task.
  - b. The Workflow is marked as CLOSED and has Failed

## 2.5 FLEXIBLE REFERRAL

In the Flexible Workflow Collaboration Circle, when a patient appears for the referral service at any hospital, that hospital completes the referral. . No Workflow Manager is involved in this process.

TABLE 2.5-1 FLEXIBLE REFERRAL WORKFLOW ACTIVITIES

STEP	ACTOR	NEXT STEP
1. Initiate Referral	Referral Requester	Go to Make Appointment.
2. Make Appointment	Referral/Transfer Receiver	Go to Pending Patient Arrival.
3. Pending Patient Arrival	Referral/Transfer Receiver	If the patient arrives for referral within a reasonable time frame go to Referral Services Initiated. If the patient does not arrive for referral within a reasonable time frame this workflow is completed and has failed.
4. Referral Services Initiated	Referral/Transfer Receiver	If referral is completed successfully this workflow is completed and has succeeded. If referral is not completed successfully this workflow is completed and has failed.

### 2.5.1 Initiate Referral

In this step, the Referral Requester Actor initiates a transfer by creating the Referral Request task, providing references to relevant Clinical Documents (e.g., Encounter Summary, Discharge Summary, Lab Result Report, Imaging Report, et cetera) and the Referral Request Document.

#### 2.5.1.1 Triggers

- The Patient Needs a Referral

#### 2.5.1.2 Actions

The Referral Requester:

1. Publishes any supporting referenced documents that have not already been shared in the HIE Infrastructure.
  - a. Ensures that the **Relevant Clinical Documents** are published.
  - b. Ensures that the **Referral Request Document** is published.
2. Creates a new Request Referral Task.
  - a. The status of the task is set to COMPLETED.
  - b. The task is assigned to the Referral Requester itself.

- c. Adds a reference to the **Relevant Clinical documents** to the **Input Documents** for the task.
- d. Adds a reference to the **Referral Request Document** to the **Output Documents** for the task.

## 2.5.2 Make Appointment

The patient and Referral/Transfer Receiver may make an appointment for the referral. If an appointment is made, the Referral/Transfer Receiver shall Transition the Perform Referral Task to the READY state and attach the Appointment as an Input of that task.

### 2.5.2.1 Triggers

- Request Referral COMPLETED

### 2.5.2.2 Actions

The Referral/Transfer Receiver:

1. Publishes any supporting referenced documents that have not already been shared in the HIE Infrastructure.
  - a. Ensures that the **Appointment Document** is published.
  - b. Ensures that the **Referral Request Document** is published.
2. Creates a new Perform Referral Task.
  - a. The status of the task is set to CREATED.
  - b. The task is assigned to the Referral/Transfer Receiver itself.
  - c. Adds a reference to the **Appointment Document** to the **Input Documents** for the task.
  - d. Adds a reference to the **Referral Request Document** to the **Input Documents** for the task.

## 2.5.3 Pending Patient Arrival

At this stage the referral has been assigned and potentially scheduled with an appointment. The Referral/Transfer Receiver Actor will report on the status of the referral based upon patient arrival.

### 2.5.3.1 Triggers

- Perform Referral CREATED

### 2.5.3.2 Actions

#### ***2.5.3.2.1 The Patient arrives for referral within a reasonable time frame***

The Referral/Transfer Receiver:

1. Publishes any supporting referenced documents that have not already been shared in the HIE Infrastructure.
  - a. Ensures that the **Referral Request Document** is published.

- b. Ensures that the **Referral/Transfer Response Document** is published.
2. Transitions the Perform Referral Task to IN\_PROGRESS.
  - a. Adds a reference to the **Referral Request Document** to the **Input Documents** for the task.
  - b. Adds a reference to the **Referral/Transfer Response Document** to the **Output Documents** for the task.

#### ***2.5.3.2.2 The Patient does not arrive for Referral within a reasonable time frame***

The Referral/Transfer Receiver:

1. Publishes any supporting referenced documents that have not already been shared in the HIE Infrastructure.
  - a. Ensures that the **Referral Request Document** is published.
2. Transitions the Perform Referral Task to FAILURE.
  - a. Adds a reference to the **Referral Request Document** to the **Input Documents** for the task.
  - b. The Workflow is marked as CLOSED and has Failed

### **2.5.4 Referral Services Initiated**

At this stage the referral services have started. The Referral/Transfer Receiver Actor will report on the status of the completion of those services.

#### **2.5.4.1 Triggers**

- Perform Referral IN\_PROGRESS

#### **2.5.4.2 Actions**

##### ***2.5.4.2.1 Referral is Completed Successfully***

When the services are complete the Perform Referral task will be transitioned to the COMPLETED state, and the results of the services will be recorded as one or more Output Documents on the Perform Referral Task.

The Referral/Transfer Receiver:

1. Publishes any supporting referenced documents that have not already been shared in the HIE Infrastructure.
  - a. Ensures that the **Referral Request Document** is published.
  - b. Ensures that the **Referral Result Document** is published.
2. Transitions the Perform Referral Task to COMPLETED.
  - a. Adds a reference to the **Referral Request Document** to the **Input Documents** for the task.
  - b. Adds a reference to the **Referral Result Document** to the **Output Documents** for the task.
  - c. The Workflow is marked as CLOSED and has Succeeded.

##### ***2.5.4.2.2 Referral is not Completed Successfully***

If the services could not be completed the Perform Referral task will be transitioned to the FAILURE state, and any partial results will be recorded as one or more Output Documents on the Perform Referral Task.

The Referral/Transfer Receiver:

1. Publishes any supporting referenced documents that have not already been shared in the HIE Infrastructure.
  - a. Ensures that the **Referral Request Document** is published.
  - b. Ensures that the **Referral Result Document** is published.
2. Transitions the Perform Referral Task to FAILURE.
  - a. Adds a reference to the **Referral Request Document** to the **Input Documents** for the task.
  - b. Adds a reference to the **Referral Result Document** to the **Output Documents** for the task.
  - c. The Workflow is marked as CLOSED and has Failed.

### 3. CORE INTEROPERABILITY SPECIFICATION REQUIREMENTS

#### 3.1 ACTOR MAPPING TO SAUDI EHEALTH INTEROPERABILITY SPECIFICATIONS

A system conforming to this Core Interoperability Specification shall claim conformance at the level of a Use Case Actor. A system may claim conformance to one or more Use Case Actors. Multiple systems may fulfill a single Use Case Actor.

The Use Case Actors and the Services they support are described at a functional level in UC0010 *Saudi eHealth eReferral and eTransfer Use Case*. Services may be required, conditional or optional. The Use Case Actors, Service(s) and Optionality are conveyed in the first three columns of Interoperability Conformance Requirement tables shown below.

The second part of the table (columns 4-7) provides the mapping for the Use Case Actor to the detailed specifications (such as IHE Profiles, Technical Actors, Optionality) that systems shall implement to exchange healthcare information in the context of this Use Case.

For a selected Use Case Actor (a single row in the table), all the requirements listed in the second part of the table (columns 4-7) shall be implemented. This includes the referenced profiles and the standards specified (terminology or other). For each Technical Actor (whether required or optional), the last column references the detailed specification that constrain and extend the implementation of this profile for KSA specific requirements (including information on where the requirements are specified). These specifications may be found in Sections in this core specification or in other referenced Saudi eHealth Interoperability Specifications (e.g. Saudi eHealth Security and Privacy Interoperability Specification, etc.).

TABLE 3.1-1 INTEROPERABILITY CONFORMANCE REQUIREMENTS FOR TRANSFER REQUESTER

REFERRAL WORKFLOW			MAPPING TO TECHNICAL CONSTRUCTS OF SAUDI EHEALTH INTEROPERABILITY SPECIFICATIONS			
USE CASE ACTOR	SERVICE SUPPORTED	OPT	TECHNICAL ACTOR	OPT	PROFILE/ STANDARD	REFERENCED SPECIFICATION AND COMMENTS
Transfer Requester	Manage Referral or Transfer	R	XDW Content Creator	R	IHE – Cross-Enterprise Document Workflow (XDW)	See Sections 4.1 and 4.2
			XDW Content Updater	R	IHE – Cross-Enterprise Document Workflow (XDW)	See Sections 4.1 and 4.2
			Content Creator	R	IHE – IT Infrastructure Scanned Document (SD)	IS0106 Saudi eHealth Clinical Documents Constrains Interoperability Specifications – Section 5.11



REFERRAL WORKFLOW			MAPPING TO TECHNICAL CONSTRUCTS OF SAUDI EHEALTH INTEROPERABILITY SPECIFICATIONS			
USE CASE ACTOR	SERVICE SUPPORTED	OPT	TECHNICAL ACTOR	OPT	PROFILE/ STANDARD	REFERENCED SPECIFICATION AND COMMENTS
					IHE – Patient Care Coordination Technical Framework	IS0106 Saudi eHealth Clinical Documents Constrains Interoperability Specifications – Section 5.12
			Document Source	R	IHE – Cross-Enterprise Document Sharing (XDS.b)	IS0102 Saudi eHealth Document Sharing Interoperability Specification – Section 3.2
			Secure Node	R	IHE Audit Trail and Node Authentication (ATNA)	IS0101 Saudi eHealth Security and Privacy Interoperability Specification – Section 3.2 and 3.3.2
			Time Client	R	IHE Consistent Time (CT)	IS0101 Saudi eHealth Security and Privacy Interoperability Specification – Section 3.1.2
	Query/Retrieve Documents	R	XDW Content Updater	R	IHE – Cross-Enterprise Document Workflow (XDW)	See Sections 4.1 and 4.2
			Document Consumer	R	IHE – Cross-Enterprise Document Sharing (XDS.b)	IS0102 Saudi eHealth Document Sharing Interoperability Specification – Section 3.3
			Content Consumer	R	IHE – IT Infrastructure Scanned Document (SD)	IS0106 Saudi eHealth Clinical Documents Constrains Interoperability Specifications – Section 5.11
		IHE – Patient Care Coordination Technical Framework			IS0106 Saudi eHealth Clinical Documents Constrains Interoperability Specifications – Section 5.12	
		IHE – Patient Care Coordination Technical Framework			IS0106 Saudi eHealth Clinical Documents Constrains Interoperability Specifications – Section 5.13	

REFERRAL WORKFLOW			MAPPING TO TECHNICAL CONSTRUCTS OF SAUDI EHEALTH INTEROPERABILITY SPECIFICATIONS			
USE CASE ACTOR	SERVICE SUPPORTED	OPT	TECHNICAL ACTOR	OPT	PROFILE/ STANDARD	REFERENCED SPECIFICATION AND COMMENTS
			X-Service User	R	IHE – Cross-Enterprise User Assertion (XUA)	IS0101 Saudi eHealth Security and Privacy Interoperability Specification – Section 3.4.1
			Secure Node	R	IHE Audit Trail and Node Authentication (ATNA)	IS0101 Saudi eHealth Security and Privacy Interoperability Specification – Sections 3.2 and 3.3.2
			Time Client	R	IHE Consistent Time (CT)	IS0101 Saudi eHealth Security and Privacy Interoperability Specification – Section 3.1.2
	Notification of Document Availability	R	Document Metadata Notification Recipient	R	IHE - Document Metadata Subscription (DSUB)	IS0102 Saudi eHealth Document Sharing Interoperability Specification – Section 4.2
			Secure Node	R	IHE Audit Trail and Node Authentication (ATNA)	IS0101 Saudi eHealth Security and Privacy Interoperability Specification – Section 3.2 and 3.3.2
			Time Client	R	IHE Consistent Time (CT)	IS0101 Saudi eHealth Security and Privacy Interoperability Specification – Section 3.1.2

*R=Required, O = Optional, C= Conditional*

*TABLE 3.1-2 INTEROPERABILITY CONFORMANCE REQUIREMENTS FOR REFERRAL REQUESTER*

REFERRAL WORKFLOW			MAPPING TO TECHNICAL CONSTRUCTS OF SAUDI EHEALTH INTEROPERABILITY SPECIFICATIONS			
USE CASE ACTOR	SERVICE SUPPORTED	OPT	TECHNICAL ACTOR	OPT	PROFILE/ STANDARD	REFERENCED SPECIFICATION AND COMMENTS
Referral Requester	Manage Referral or Transfer	R	XDW Content Creator	R	IHE – Cross-Enterprise Document Workflow (XDW)	See Sections 4.1 and 4.3

REFERRAL WORKFLOW			MAPPING TO TECHNICAL CONSTRUCTS OF SAUDI EHEALTH INTEROPERABILITY SPECIFICATIONS				
USE CASE ACTOR	SERVICE SUPPORTED	OPT	TECHNICAL ACTOR	OPT	PROFILE/ STANDARD	REFERENCED SPECIFICATION AND COMMENTS	
			XDW Content Updater	R	IHE – Cross-Enterprise Document Workflow (XDW)	See Sections 4.1 and 4.3	
			Content Creator	R	IHE – IT Infrastructure Scanned Document (SD)	IS0106 Saudi eHealth Clinical Documents Constrains Interoperability Specifications – Section 5.11	
					IHE – Patient Care Coordination Technical Framework	IS0106 Saudi eHealth Clinical Documents Constrains Interoperability Specifications – Sections 5.12	
			Document Source	R	IHE – Cross-Enterprise Document Sharing (XDS.b)	IS0102 Saudi eHealth Document Sharing Interoperability Specification – Section 3.2	
			Secure Node	R	IHE Audit Trail and Node Authentication (ATNA)	IS0101 Saudi eHealth Security and Privacy Interoperability Specification – Section 3.2 and 3.3.2	
			Time Client	R	IHE Consistent Time (CT)	IS0101 Saudi eHealth Security and Privacy Interoperability Specification – Section 3.1.2	
		Query/Retrieve Documents	R	XDW Content Updater	R	IHE – Cross-Enterprise Document Workflow (XDW)	See Sections 4.1 and 4.3
				Document Consumer	R	IHE – Cross-Enterprise Document Sharing (XDS.b)	IS0102 Saudi eHealth Document Sharing Interoperability Specification – Section 3.3
				Content Consumer	R	IHE – IT Infrastructure Scanned Document (SD)	IS0106 Saudi eHealth Clinical Documents Constrains Interoperability Specifications – Section 5.11

REFERRAL WORKFLOW			MAPPING TO TECHNICAL CONSTRUCTS OF SAUDI EHEALTH INTEROPERABILITY SPECIFICATIONS						
USE CASE ACTOR	SERVICE SUPPORTED	OPT	TECHNICAL ACTOR	OPT	PROFILE/ STANDARD	REFERENCED SPECIFICATION AND COMMENTS			
					IHE – Patient Care Coordination Technical Framework	IS0106 Saudi eHealth Clinical Documents Constrains Interoperability Specifications – Section 5.12			
					IHE – Patient Care Coordination Technical Framework	IS0106 Saudi eHealth Clinical Documents Constrains Interoperability Specifications – Section 5.13			
					Internet Calendaring and Scheduling Core Object Specification (iCalendar)– RFC 5545	See Section 5.1.2			
						X-Service User	R	IHE – Cross-Enterprise User Assertion (XUA)	IS0101 Saudi eHealth Security and Privacy Interoperability Specification – Section 3.4.1
						Secure Node	R	IHE Audit Trail and Node Authentication (ATNA)	IS0101 Saudi eHealth Security and Privacy Interoperability Specification – Sections 3.2 and 3.3.2
						Time Client	R	IHE Consistent Time (CT)	IS0101 Saudi eHealth Security and Privacy Interoperability Specification – Section 3.1.2
				Notification of Document Availability	R	Document Metadata Notification Recipient	R	IHE - Document Metadata Subscription (DSUB)	IS0102 Saudi eHealth Document Sharing Interoperability Specification – Section 4.2
			Secure Node	R	IHE Audit Trail and Node Authentication (ATNA)	IS0101 Saudi eHealth Security and Privacy Interoperability Specification – Section 3.2 and 3.3.2			

REFERRAL WORKFLOW			MAPPING TO TECHNICAL CONSTRUCTS OF SAUDI EHEALTH INTEROPERABILITY SPECIFICATIONS			
USE CASE ACTOR	SERVICE SUPPORTED	OPT	TECHNICAL ACTOR	OPT	PROFILE/ STANDARD	REFERENCED SPECIFICATION AND COMMENTS
			Time Client	R	IHE Consistent Time (CT)	IS0101 Saudi eHealth Security and Privacy Interoperability Specification – Section 3.1.2

*R=Required, O = Optional, C= Conditional*

*TABLE 3.1-3 INTEROPERABILITY CONFORMANCE REQUIREMENTS FOR WORKFLOW MANAGER*

REFERRAL WORKFLOW			MAPPING TO TECHNICAL DOCUMENTS OF SAUDI EHEALTH INTEROPERABILITY SPECIFICATIONS			
USE CASE ACTOR	SERVICE SUPPORTED	OPT	TECHNICAL ACTOR	OPT	PROFILE/ STANDARD	REFERENCED SPECIFICATION AND COMMENTS
Workflow Manager	Manage Referral or Transfer	R	XDW Content Updater	R	IHE – Cross-Enterprise Document Workflow (XDW)	See Sections 4.1 and 4.4
			Document Source	R	IHE – Cross-Enterprise Document Sharing (XDS.b)	IS0102 Saudi eHealth Document Sharing Interoperability Specification – Section 3.2
			Content Creator	R	IHE – Patient Care Coordination Technical Framework	IS0106 Saudi eHealth Clinical Documents Constrains Interoperability Specifications – Section 5.13 Referral/Transfer Response Document
			Secure Node	R	IHE Audit Trail and Node Authentication (ATNA)	IS0101 Saudi eHealth Security and Privacy Interoperability Specification – Section 3.2 and 3.3.2
			Time Client	R	IHE Consistent Time (CT)	IS0101 Saudi eHealth Security and Privacy Interoperability Specification – Section 3.1.2
	Query/Retrieve Documents	R	XDW Content Updater	R	IHE – Cross-Enterprise Document Workflow (XDW)	See Sections 4.1 and 4.4

REFERRAL WORKFLOW			MAPPING TO TECHNICAL DOCUMENTS OF SAUDI EHEALTH INTEROPERABILITY SPECIFICATIONS			
USE CASE ACTOR	SERVICE SUPPORTED	OPT	TECHNICAL ACTOR	OPT	PROFILE/ STANDARD	REFERENCED SPECIFICATION AND COMMENTS
			Document Consumer		IHE – Cross-Enterprise Document Sharing (XDS.b)	IS0102 Saudi eHealth Document Sharing Interoperability Specification – Section 3.3
			Content Consumer	R	IHE – IT Infrastructure Scanned Document (SD)	IS0106 Saudi eHealth Clinical Documents Constrains Interoperability Specifications – Section 5.11
		IHE – Patient Care Coordination Technical Framework			IS0106 Saudi eHealth Clinical Documents Constrains Interoperability Specifications – Section 5.12	
		IHE – Patient Care Coordination Technical Framework			IS0106 Saudi eHealth Clinical Documents Constrains Interoperability Specifications – Section 5.13	
		Internet Calendaring and Scheduling Core Object Specification (iCalendar)– RFC 5545			See Section 5.1.2	
			X-Service User	R	IHE – Cross-Enterprise User Assertion (XUA)	IS0101 Saudi eHealth Security and Privacy Interoperability Specification – Section 3.4.1
			Secure Node	R	IHE Audit Trail and Node Authentication (ATNA)	IS0101 Saudi eHealth Security and Privacy Interoperability Specification – Sections 3.2 and 3.3.2
			Time Client	R	IHE Consistent Time (CT)	IS0101 Saudi eHealth Security and Privacy Interoperability Specification – Section 3.1.2
	Notification of Document Availability	R	Document Metadata Notification Recipient	R	IHE - Document Metadata Subscription (DSUB)	IS0102 Saudi eHealth Document Sharing Interoperability Specification – Section 4.2

REFERRAL WORKFLOW			MAPPING TO TECHNICAL DOCUMENTS OF SAUDI EHEALTH INTEROPERABILITY SPECIFICATIONS			
USE CASE ACTOR	SERVICE SUPPORTED	OPT	TECHNICAL ACTOR	OPT	PROFILE/ STANDARD	REFERENCED SPECIFICATION AND COMMENTS
			Secure Node	R	IHE Audit Trail and Node Authentication (ATNA)	IS0101 Saudi eHealth Security and Privacy Interoperability Specification – Section 3.2 and 3.3.2
			Time Client	R	IHE Consistent Time (CT)	IS0101 Saudi eHealth Security and Privacy Interoperability Specification – Section 3.1.2

R=Required, O = Optional, C= Conditional

TABLE 3.1-4 INTEROPERABILITY CONFORMANCE REQUIREMENTS FOR REFERRAL/TRANSFER RECEIVER

REFERRAL WORKFLOW			MAPPING TO TECHNICAL CONSTRUCTS OF SAUDI EHEALTH INTEROPERABILITY SPECIFICATIONS			
USE CASE ACTOR	SERVICE SUPPORTED	OPT	TECHNICAL ACTOR	OPT	PROFILE/STANDARD	REFERENCED SPECIFICATION AND COMMENTS
Referral/ Transfer Receiver	Manage Referral or Transfer		XDW Content Updater	R	IHE – Cross-Enterprise Document Workflow (XDW)	See Sections 4.1 and 4.5
			Content Creator	R	IHE – IT Infrastructure Scanned Document (SD)	IS0106 Saudi eHealth Clinical Documents Constrains Interoperability Specifications – Section 5.11
					IHE – Patient Care Coordination Technical Framework	IS0106 Saudi eHealth Clinical Documents Constrains Interoperability Specifications – Section 5.13 Referral/Transfer Response Document
					Internet Calendaring and Scheduling Core Object Specification (iCalendar)– RFC 5545	See Section 5.1.2

REFERRAL WORKFLOW			MAPPING TO TECHNICAL CONSTRUCTS OF SAUDI EHEALTH INTEROPERABILITY SPECIFICATIONS			
USE CASE ACTOR	SERVICE SUPPORTED	OPT	TECHNICAL ACTOR	OPT	PROFILE/STANDARD	REFERENCED SPECIFICATION AND COMMENTS
			Document Source	R	IHE – Cross-Enterprise Document Sharing (XDS.b)	IS0102 Saudi eHealth Document Sharing Interoperability Specification – Section 3.2
			Secure Node	R	IHE Audit Trail and Node Authentication (ATNA)	IS0101 Saudi eHealth Security and Privacy Interoperability Specification – Section 3.2 and 3.3.2
			Time Client	R	IHE Consistent Time (CT)	IS0101 Saudi eHealth Security and Privacy Interoperability Specification – Section 3.1.2
	Query/Retrieve Documents	R	XDW Content Updater	R	IHE – Cross-Enterprise Document Workflow (XDW)	See Sections 4.1 and 4.5
			Document Consumer	R	IHE – Cross-Enterprise Document Sharing (XDS.b)	IS0102 Saudi eHealth Document Sharing Interoperability Specification Section 3.3
			Content Consumer	R	IHE – IT Infrastructure Scanned Document (SD)	IS0106 Saudi eHealth Clinical Documents Constrains Interoperability Specifications – Section 5.11
		IHE – Patient Care Coordination Technical Framework			IS0106 Saudi eHealth Clinical Documents Constrains Interoperability Specifications – Section 5.12  Referral Request Document or Transfer Request Document	
		IHE – Patient Care Coordination Technical Framework			IS0106 Saudi eHealth Clinical Documents Constrains Interoperability Specifications – Section 5.13 Referral/Transfer Response Document	



REFERRAL WORKFLOW			MAPPING TO TECHNICAL CONSTRUCTS OF SAUDI EHEALTH INTEROPERABILITY SPECIFICATIONS			
USE CASE ACTOR	SERVICE SUPPORTED	OPT	TECHNICAL ACTOR	OPT	PROFILE/STANDARD	REFERENCED SPECIFICATION AND COMMENTS
					Internet Calendaring and Scheduling Core Object Specification (iCalendar)– RFC 5545	See Section 5.1.2
			X-Service User	R	IHE – Cross-Enterprise User Assertion (XUA)	IS0101 Saudi eHealth Security and Privacy Interoperability Specification – Section 3.4.1
			Secure Node	R	IHE Audit Trail and Node Authentication (ATNA)	IS0101 Saudi eHealth Security and Privacy Interoperability Specification – Sections 3.2 and 3.3.2
			Time Client	R	IHE Consistent Time (CT)	IS0101 Saudi eHealth Security and Privacy Interoperability Specification – Section 3.1.2
	Notification of Document Availability	R	Document Metadata Notification Recipient	R	IHE - Document Metadata Subscription (DSUB)	IS0102 Saudi eHealth Document Sharing Interoperability Specification – Section 4.2
			Secure Node	R	IHE Audit Trail and Node Authentication (ATNA)	IS0101 Saudi eHealth Security and Privacy Interoperability Specification – Section 3.2 and 3.3.2
			Time Client	R	IHE Consistent Time (CT)	IS0101 Saudi eHealth Security and Privacy Interoperability Specification – Section 3.1.2

*R=Required, O = Optional, C= Conditional*

TABLE 3.1-5 INTEROPERABILITY CONFORMANCE REQUIREMENTS FOR HIE DOCUMENT REPOSITORY

REFERRAL WORKFLOW			MAPPING TO TECHNICAL DOCUMENTS OF SAUDI EHEALTH INTEROPERABILITY SPECIFICATIONS			
USE CASE ACTOR	SERVICE SUPPORTED	OPT	TECHNICAL ACTOR	OPT	PROFILE/ STANDARD	REFERENCED SPECIFICATION AND COMMENTS
HIE Document Repository	Publish Document(s)	R	Document Repository	R	IHE – Cross-Enterprise Document Sharing (XDS.b)	IS0102 Saudi eHealth Document Sharing Interoperability Specification – Section 3.4
			Secure Node	R	IHE Audit Trail and Node Authentication (ATNA)	IS0101 Saudi eHealth Security and Privacy Interoperability Specification – Section 3.2 and 3.3.1
			Time Client	R	IHE Consistent Time (CT)	IS0101 Saudi eHealth Security and Privacy Interoperability Specification – Section 3.1.2
	Query/Retrieve Document(s)	R	Document Registry and Document Repository	R	IHE – Cross-Enterprise Document Sharing (XDS.b)	IS0102 Saudi eHealth Document Sharing Interoperability Specification – Section 3.4
			X-Service Provider	R	IHE – Cross-Enterprise User Assertion (XUA)	IS0101 Saudi eHealth Security and Privacy Interoperability Specification – Section 3.4.2
			Secure Node	R	IHE Audit Trail and Node Authentication (ATNA)	IS0101 Saudi eHealth Security and Privacy Interoperability Specification – Section 3.2 and 3.3.1
			Time Client	R	IHE Consistent Time (CT)	IS0101 Saudi eHealth Security and Privacy Interoperability Specification – Section 3.1.2
	Notification of Document Availability	R	Document Metadata Notification Broker	R	IHE - Document Metadata Subscription (DSUB)	IS0102 Saudi eHealth Document Sharing Interoperability Specification – Section 4.1
			Secure Node	R	IHE Audit Trail and Node Authentication (ATNA)	IS0101 Saudi eHealth Security and Privacy Interoperability Specification – Section 3.2 and 3.3.1
			Time Client	R	IHE Consistent Time (CT)	IS0101 Saudi eHealth Security and Privacy Interoperability Specification – Section 3.1.2

*R=Required, O = Optional, C= Conditional*

## 3.2 INTEROPERABILITY SEQUENCE DIAGRAMS

The following Sequence diagrams provide an overview of the combined flow of transactions resulting from the above selected profiles and standards. The Main Flow Sequence Diagram illustrates a very common (i.e., typical) workflow and other sequence diagrams are shown to provide an alternative or exception to the main flow. Other sequence diagrams are possible but they cover the same key transactions with slight variants of information exchange between the Use Case Actors, therefore, have been omitted.

The Referral and Transfer Workflow sequence diagrams provide a high level sequence of events for the exchange of information that culminates in the transfer or referral of a patient between facilities. It also illustrates typical security exchanges for authorized network communications and audit trail of patient information access.

In the case of Referral and Transfer, there are two (2) Flow Sequence Diagrams shown. The Main Flow Sequence Diagram includes:

**Simple Collaboration Circle Based Transfer:** a scenario wherein a transfer request is made to multiple Referral/Transfer Receivers within a Collaboration Circle and the first Referral/Transfer Receiver that accepts the request is chosen to perform the transfer.

Note: A Collaboration Circle is defined as a number of Referral or Transfer Requesters and potential Referral/Transfer Receivers that have been granted membership by a Workflow Manager. They operate according to specific set of rules agreed upon by the members of the Collaboration Circle. These rules are outside the scope of this Core Interoperability Specification. The HIE Platform is configured so that it knows the Workflow Manager of each Collaboration Circle in the KSA. It is integral to the design of the Workflow Manager to know the membership and the rules that apply to the Collaboration Circle in processing referral or transfer requests and responses. For more details see UC0010 *Saudi eHealth eReferral and eTransfer Use Case*.

The following is the Alternate Flow Sequence Diagram:

- **Directed Referral** is a referral request that is assigned to a specific Referral/Transfer Receiver. Any other Referral/Transfer Receiver attempting will be unable to accept the Request.

### 3.2.1 Sequence diagram pre-conditions

The sequence diagram depicts Use Case Actors and a number of transactions between IHE Profile Actors specified in the tables in Section 3.1 Actor mapping to Saudi eHealth Interoperability Specifications. A number of pre-conditions must exist in order to enable the main, alternative and exception sequence diagrams.

1. Prior to retrieving Referral/Transfer Documents from the HIE Document Repository or creating documents to share on the HIE Document Repository; the Healthcare Provider or Organization **SHALL** obtain the KSA-Wide Health ID. The requirements on how to obtain a patient's KSA-Wide Health ID and key patient demographics are defined in IS0001 *Saudi eHealth Core Interoperability Specification for KSA-Wide Patient Demographic Query*. The Health ID and key patient demographic attributes are used to identify the patient for which the prescriptions and medications are shared.

This ensures KSA-Wide identification of the patient in health records. This is not shown in any of the sequence diagrams, and the details to accomplish this are defined in IS0001 *Saudi eHealth Core Interoperability Specification for KSA-Wide Patient Demographic Query*.

2. The [IHE XDS.b: Register Document Set – b ITI-42] transaction is listed without first performing the authentication between the two systems [IHE ATNA Profile: Authenticate Node ITI-19]. This is because it is very common that the HIE Document Repository and Registry are implemented within the same system. If these Actors are implemented in separate systems the authentication transaction would be required.
3. When querying and retrieving referral or transfer workflow and attachment documents, the [IHE XDS-b: Profile: Registry Stored Query ITI-18] and [IHE XDS-b: Retrieve Document Set ITI-43] transitions are listed without first performing the authentication between the two systems [IHE ATNA Profile: Authenticate Node ITI-19]. The IHE ATNA transaction is required to be performed.

The following transactions must occur prior to the start of the main, alternative or exception Sequences:

1. Time synchronization shall occur at least once prior to communicating between the HIE System and the Referral or Transfer Actors.
2. Before the information exchanges can take place, an authentication process takes place between the Referral or Transfer/Secure Node Actor and the HIE System/Secure Node Actor occurs [IHE ATNA Profile: Authenticate Node ITI-19].

Note: It is assumed that once a secure connection has been established, it will be maintained. If this is not the case, then an additional authentication transaction will need to occur before continuing any exchange transactions.

Figure 3.2-1 Pre-condition Sequence Diagram depicts the pre-condition in the case that the Referral or Transfer Use Case Actor is acting as an appropriate Technical Actor (e.g. Referral or Transfer Use Case Actor acting as a Document Source, etc.).

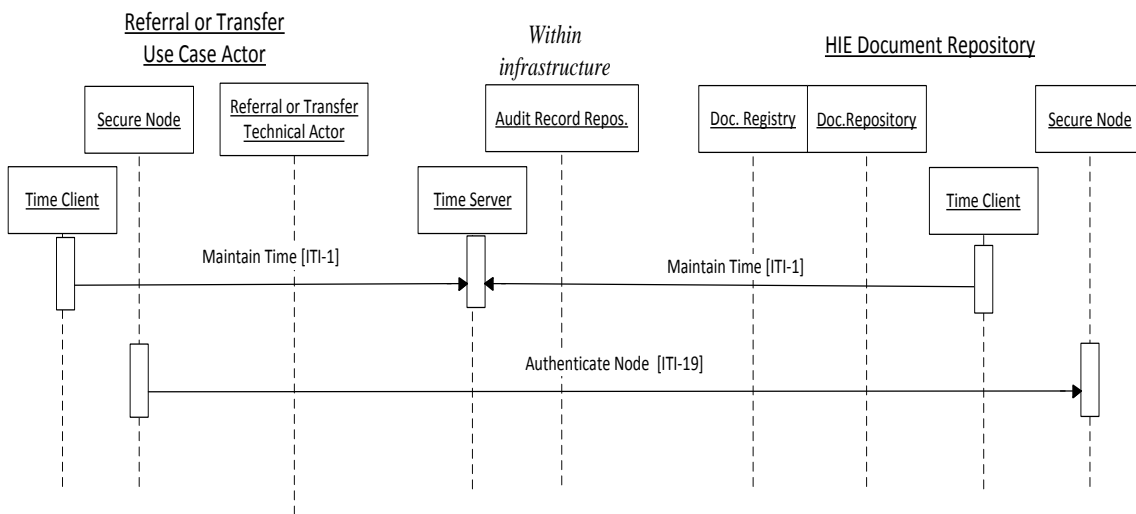

FIGURE 3.2-1 PRE-CONDITION SEQUENCE DIAGRAM

### 3.2.2 Other sequence diagram requirements

In order to simplify the sequence diagrams, the following transaction pairing should be taken into account.

#### 3.2.2.1 Registry Stored Query to the HIE Document Repository

Figure 3.2-2 Transactions associated with a Registry Stored Query depicts the transactions associated with a Registry Stored Query. When a query is made from the Referral or Transfer Use Case Actor/Document Consumer to the HIE Document Repository, the following transactions **SHALL** all take place.

1. The Referral or Transfer Use Case Actor/Document Consumer sends a query request. As part of the query request, a user assertion is conveyed to verify that the Healthcare Provider or Organization is an authorized user to obtain patient information [IHE XDS-b: Registry Stored Query ITI-18] and [IHE XUA: Provide X-User Assertion ITI-40].  
The Referral or Transfer Use Case Actor/Secure Node generates a local audit record of the access to patient health information [using the data content as defined by IHE ATNA Profile and the appropriate technical actor's ATNA conformance requirements].
2. The HIE Document Repository/Secure Node generates an audit record of the receipt of patient health information [IHE ATNA Profile: Record Audit Event ITI-20].

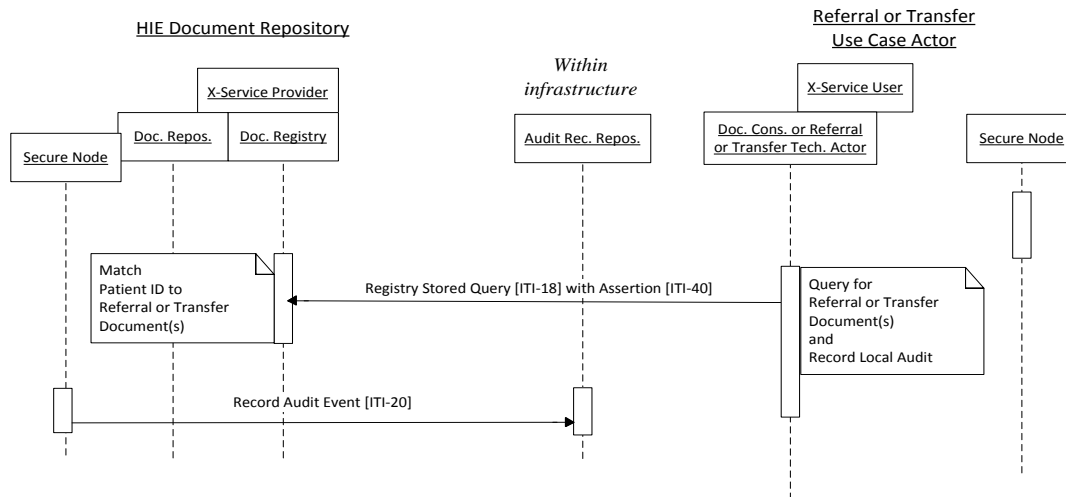

FIGURE 3.2-2 TRANSACTIONS ASSOCIATED WITH A REGISTRY STORED QUERY

#### 3.2.2.2 Retrieve Referral/Transfer Documents from the HIE Document Repository

Figure 3.2-3 Transactions Associated with a Document Retrieval depicts the transactions associated with Referral/Transfer Document(s) retrieval from the HIE Document Repository.

When document(s) are retrieved from the HIE Document Repository, the following transactions must all take place.

1. The Referral or Transfer Use Case Actor/X-Service User retrieves the document(s). As part of the retrieve, a user assertion is conveyed to verify that the Healthcare Provider or Organization is an authorized user to obtain patient information [IHE XDS-b: Retrieve Document Set ITI-43] and [IHE XUA: Provide X-User Assertion ITI-40].

The Referral or Transfer Use Case Actor/Secure Node generates a local audit record of the access to patient health information [using the data content as defined by IHE ATNA Profile and the appropriate technical actor's ATNA conformance requirements].

2. The HIE Document Repository/Secure Node generates an audit record of the access to patient health information [IHE ATNA Profile: Record Audit Event ITI-20].

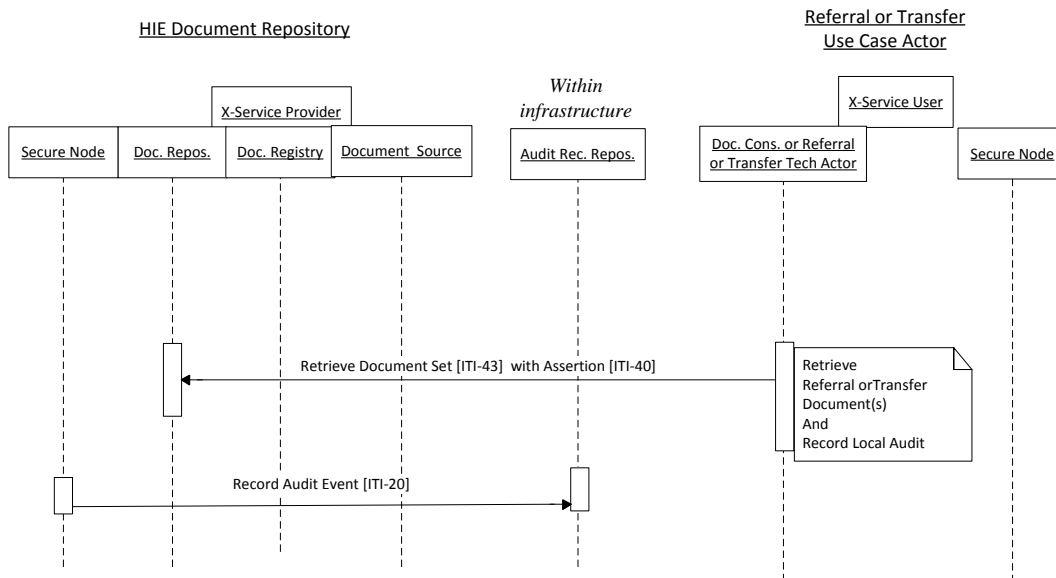

FIGURE 3.2-3 TRANSACTIONS ASSOCIATED WITH A DOCUMENT RETRIEVAL

### 3.2.2.3 Publish Referral/Transfer Document(s) to the HIE Document Repository

Figure 3.2-4 Transactions associated with Publish Document depicts the transactions associated with storage of Referral/Transfer Document(s) to the HIE Document Repository. When document(s) are stored to the HIE Document Repository, the following transactions must all take place:

1. The Referral or Transfer Use Case Actor/Document Source publishes the Referral/Transfer Document to the HIE Document Repository/Document Repository using [IHE XDS.b: Provide & Register Document Set ITI-41].
2. The HIE Document Repository registers the document with the Document Registry [IHE XDS.b: Register Document Set – b ITI-42].
3. The Referral or Transfer Use Case Actor/Secure Node generates a local audit record of the access to patient health information [using the data content as defined by IHE

ATNA Profile and the appropriate technical actor's ATNA conformance requirements. The HIE Document Repository/Secure Node generates an audit record of the receipt of patient health information [IHE ATNA Profile: Record Audit Event ITI-20].

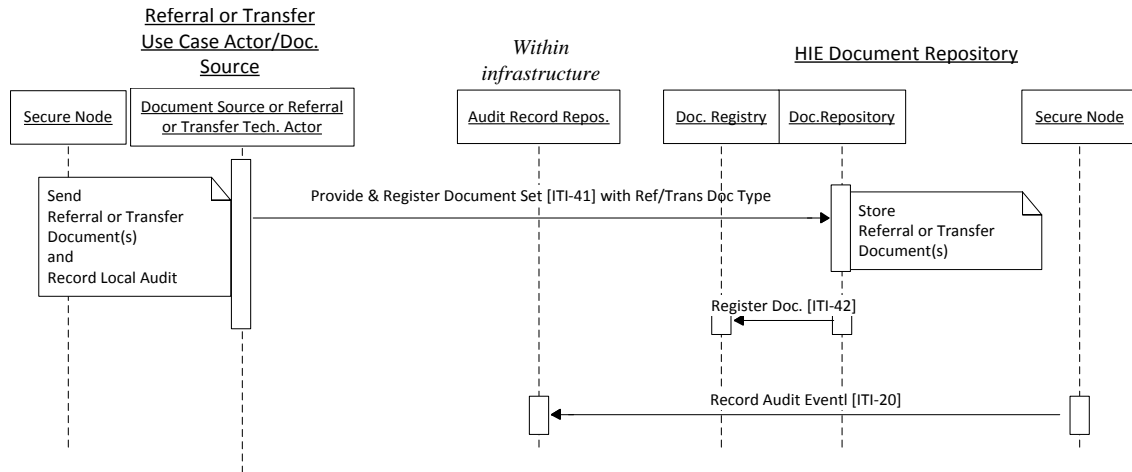

FIGURE 3.2-4 TRANSACTIONS ASSOCIATED WITH PUBLISH DOCUMENT

### 3.2.3 Main flow sequence diagrams

These sequence diagrams depict Use Case Actors and a number of transactions between IHE Profile Actors specified in the tables in Section 3.1 Actor mapping to Saudi eHealth Interoperability Specifications.

#### 3.2.3.1 Main flow sequence diagram – Simple Collaboration Circle Based Transfer flow sequence diagram

The main flow sequence diagram and the text below depict an in-patient transfer scenario within a Collaboration Circle.

The main flows are:

- Submission of a transfer request to a selected Workflow Manager via the HIE Document Repository. The Healthcare Provider also references relevant patient medical records to the request.
- The Workflow Manager dispatches the request to one or more Referral/Transfer Receivers.
- The first Referral/Transfer Receiver to accept the request is assigned by the Workflow Manager to perform the transfer. An appointment is scheduled.
- The patient shows up for the transfer and it is performed.

Note: How to obtain the relevant patient records is not defined in this IS, these specification can be obtained via the IS0007 *Saudi eHealth Core Interoperability Specification for Clinical Notes and Summaries* document.

Note: The Use Case Services are actually implemented using the underlying transaction(s) defined by the Profiles or Standards selected. Therefore, the Use Case Services are not depicted directly in the sequence diagrams.

Steps 1 – 6 are related to transfer workflow and are shown in Figure 3.2-1 Transactions Simple Collaboration Circle Based Transfer (1)

1. The patient is being provided with in-patient healthcare. As part of the care the Healthcare Provider or Organization obtained the patient's KSA-Wide Health ID and has access to the patient's medical records. See pre-conditions described in Section 3.2.1 Sequence diagram pre-conditions. Patient records are obtained using the Clinical Content Consumer as defined in the IS0007 *Saudi eHealth Core Interoperability Specification for Clinical Notes and Summaries* document.
2. The Healthcare Provider diagnoses a problem which requires services not offered by the local Healthcare Organization, thus decides to transfer the patient to a Healthcare Organization that is able to provide the needed services.
3. The Transfer Requester/XDW Content Creator/Document Source Actor publishes two documents to the HIE Document Repository [IHE XDS.b: Provide & Register Document Set ITI-41] (see Section 3.2.2.3 Publish Referral/Transfer Document(s) to the HIE Document Repository for the full set of transactions). They are a Transfer Request Document and an IHE XDW Document with a Request Transfer Task. Inputs to the task include references to relevant patient attached documents and the output of the task is the Transfer Request Document.
4. The HIE Document Repository stores the document(s) and the notification of document availability is transmitted [IHE DSUB Profile: Document Metadata Notify ITI-53] to the Workflow Manager/Notification Recipient that was identified in the IHE XDW Document.
5. The Workflow Manager/XDW Content Updater/Document Consumer retrieves the IHE XDW Document and Transfer Request Document.
6. The Workflow Manager/XDW Content Updater/Document Source updates in the IHE XDW Document with a Dispatch Transfer Task. The Workflow Manager/XDW Content Updater/Document Source updates the IHE XDW Document with a Respond to Transfer Request Task. Inputs to the task include references to relevant patient attached documents and the Transfer Request Document. The updated IHE XDW Document is published to the HIE Document Registry.

Note: This sequence diagram illustrates the “no bidding needed” workflow.



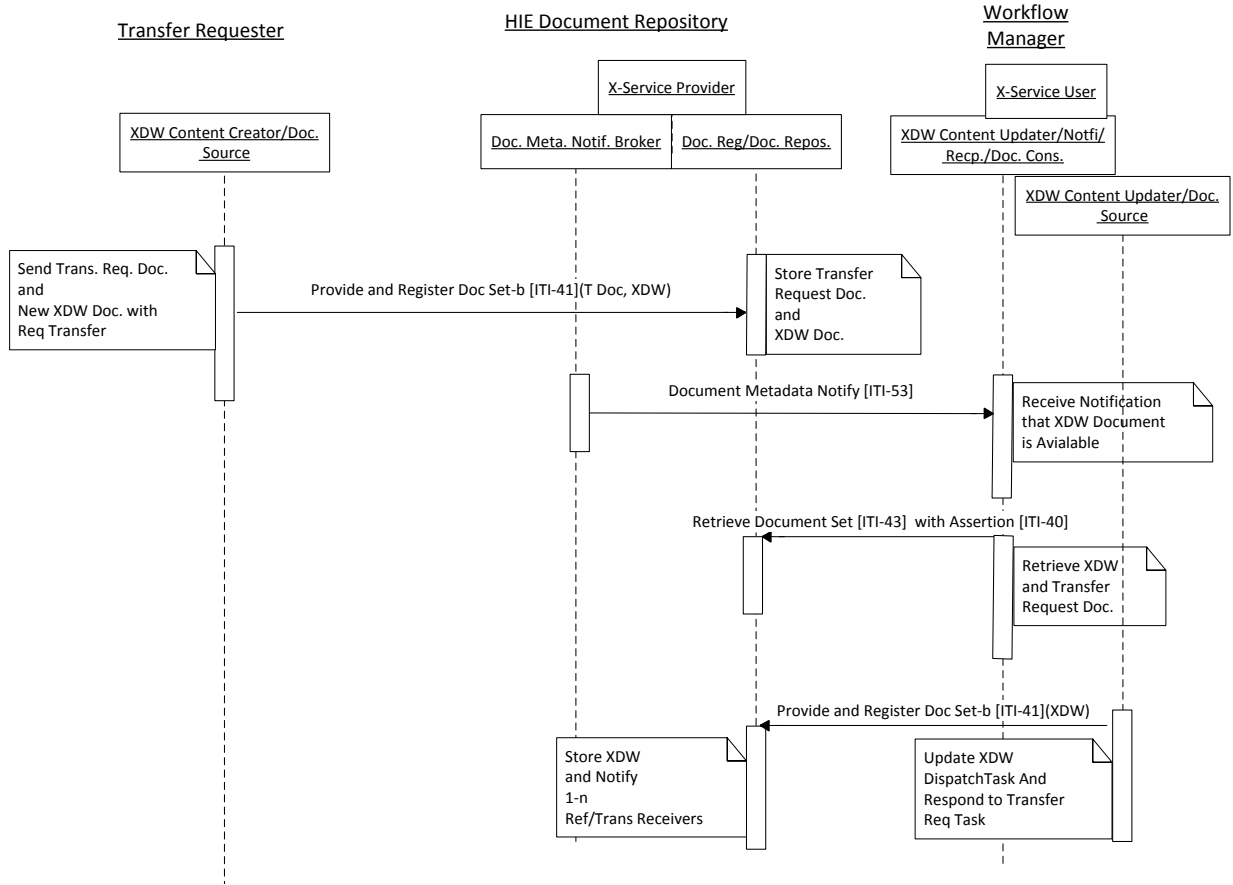

FIGURE 3.2-1 TRANSACTIONS SIMPLE COLLABORATION CIRCLE BASED TRANSFER (1)

Steps 7 – 14 are related to transfer workflow and are shown in Figure 3.2-2 Transactions Simple Collaboration Circle Based Transfer (2).

7. The notification of document availability is transmitted from the HIE Document Repository to one or more Referral/Transfer Receiver/ Notification Recipient Actors [IHE DSUB Profile: Document Metadata Notify ITI-53].
8. The Referral/Transfer Receiver/XDW Content Updater/Document Consumers retrieve the IHE XDW Document from the HIE Document Repository and processes the IHE XDW Document and retrieves the input/output documents (i.e. referenced attached documents and Transfer Request Document) from the HIE Document Repository.
9. The Referral/Transfer Receiver/XDW Content Updater/Document Source Actor (1) evaluates the transfer request and decides to accept the request. It generates a Referral/Transfer Response Document and updates in the IHE XDW Document the Respond to Transfer Request Task. The updated IHE XDW Document and a Referral/Transfer Response Document is sent to the HIE Document Repository [IHE XDS.b: Provide & Register Document Set ITI-41].

Note: Other Referral/Transfer Receiver/XDW Content Updater/Document Sources may also evaluate the transfer request. The sequence diagram only shows the first accepted response.

10. The notification of document availability is transmitted from the HIE Document Repository to the Workflow Manager/Notification Recipient [IHE DSUB Profile: Document Metadata Notify ITI-53].
11. The Workflow Manager/XDW Content Updater/Document Consumer retrieves the updated IHE XDW Document, the Referral/Transfer Response Document and other referenced attached documents.
12. The Workflow Manager/XDW Content Updater/Document Consumer process the IHE XDW Document. The Workflow Manager/XDW Content Updater/Document Source updates in the IHE XDW Document the Perform Transfer Task (i.e. the task is assigned to Referral/Transfer Receivers/XDW Content Updater/Document Source Actor (1)). The Referral/Transfer Response Document is added to the output of the task. The updated IHE XDW Document is sent to the HIE Document Repository [IHE XDS.b: Provide & Register Document Set ITI-41].
13. The notification of document availability is transmitted from the HIE Document Repository to all Referral/Transfer Receiver/Notification Recipient Actors and the Transfer Requester/Notification Recipient that submitted the request [IHE DSUB Profile: Document Metadata Notify ITI-53] (i.e. all interested Actors know the Referral or Transfer request has been accepted and assign).
14. All the notified Actors retrieve the IHE XDW Document from the HIE Document Repository. They process the IHE XDW Document and retrieve the referenced input and output documents (i.e. attached documents, Transfer Request Document) from the HIE Document Repository. This is when Referral/Transfer Receivers/XDW Content Updater/Document Source Actor (1) learns it has been selected and the other Actors learn they have not been accepted. Each Actor updates their system accordingly.

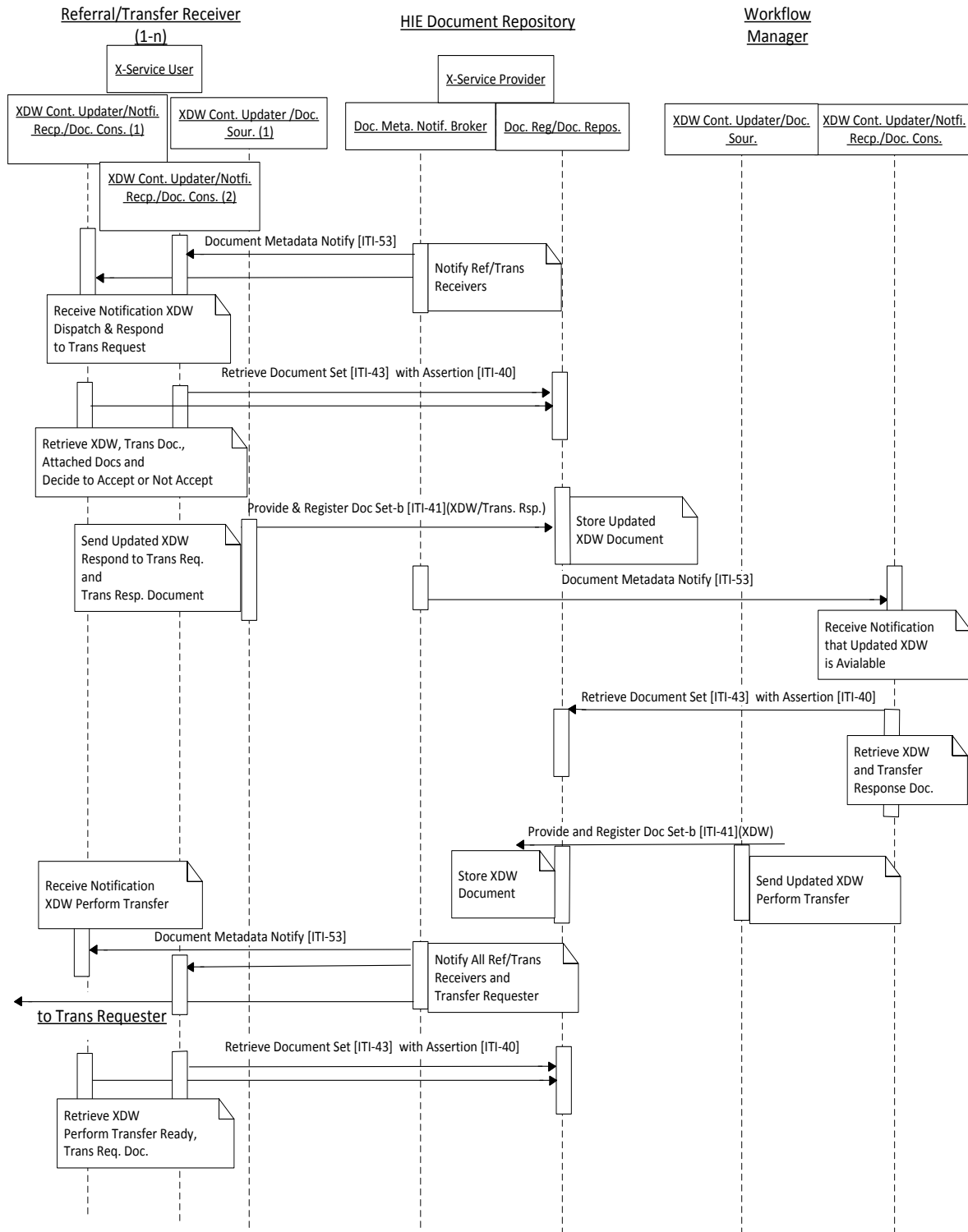

FIGURE 3.2-2 TRANSACTIONS SIMPLE COLLABORATION CIRCLE BASED TRANSFER (2)

Steps 15 – 21 are related to transfer workflow and are shown in Figure 3.2-3 Transactions Simple Collaboration Circle Based Transfer (3).

15. The patient transportation to the Referral/Transfer Receiver facility has begun. The Transfer Requester/XDW Content Updater/Document Consumer updates in the IHE XDW the Document Perform Transfer. The updated IHE XDW Document is sent to the HIE Document Repository [IHE XDS.b: Provide & Register Document Set ITI-41].
16. The notification of document availability is transmitted from the HIE Document Repository to the Referral/Transfer Receiver/Notification Recipient (1) and the Workflow Manager/Notification Recipient [IHE DSUB Profile: Document Metadata Notify ITI-53].
17. The Referral/Transfer Receiver/XDW Content Updater/Document Consumer (1) retrieves the IHE XDW Document from the HIE Document Repository, processes the IHE XDW Document and learns that the transportation has begun.
18. The patient arrives at the Referral/Transfer Receiver/XDW Content Updater/Document Consumer (1) facility and the Referral/Transfer Receiver updates in the IHE XDW Document the Perform Transfer Task. The updated IHE XDW Document is sent to the HIE Document Repository [IHE XDS.b: Provide & Register Document Set ITI-41].
19. The notification of document availability is transmitted from the HIE Document Repository to the Transfer Requester/Notification Recipient and the Workflow Manager/Notification Recipient [IHE DSUB Profile: Document Metadata Notify ITI-53].
20. The Transfer Requester/XDW Content Updater/Document Consumer retrieves the IHE XDW Document from the HIE Document Repository, processes the IHE XDW Document and learns the patient has arrived and has been admitted to the Referral/Transfer Receiver (1) facility.
21. The Transfer is completed and the patient is provided healthcare.

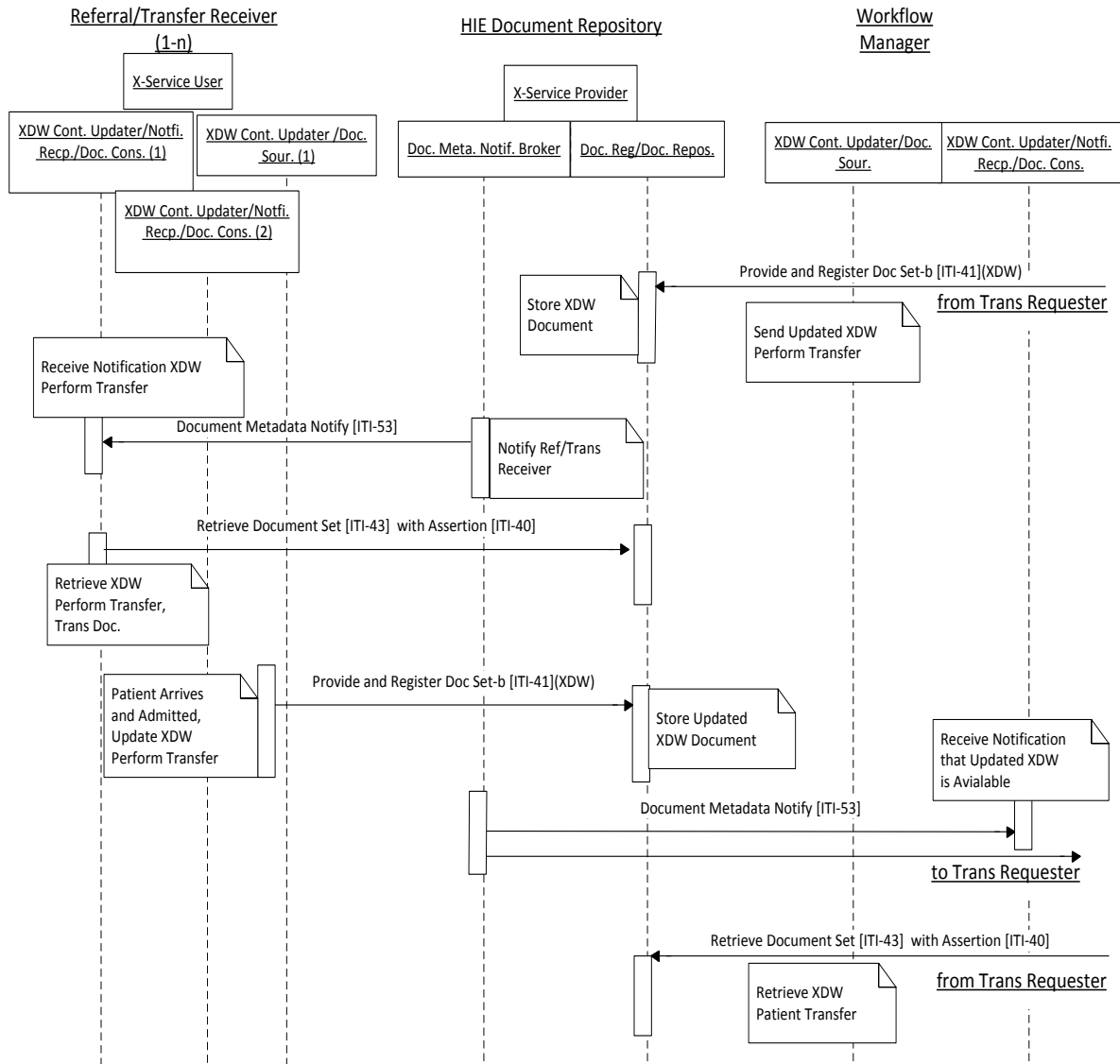

FIGURE 3.2-3 TRANSACTIONS SIMPLE COLLABORATION CIRCLE BASED TRANSFER (3)

### 3.2.4 Alternate flow sequence diagrams

These sequence diagrams indicate additional transactions that may occur between the Use Case Actors.

#### 3.2.4.1 Alternative flow sequence diagram – Directed Referral flow sequence diagram

The alternative flow sequence diagram and the text below depict a directed referral scenario where a Referral Requestor assigns the referral to a specific Referral/Transfer Receiver. The Workflow Manager Actor is not included in the workflow.

The Alternative flows are:

- A Referral Requester issues to the HIE Document Repository a request that is assigned to a specific Referral/transfer Receiver.
- The specific Referral/Transfer Receiver is notified of the request.
- The Referral/Transfer Receiver reviews the request and determines it needs additional information in order to accept the referral.
- The Referral Requester provides the additional information.
- The Referral/Transfer Receiver accepts the referral.

Note: How to obtain the relevant patient records is not defined in this IS, these specification can be obtained via the IS0007 *Saudi eHealth Core Interoperability Specification for Clinical Notes and Summaries* document.

Note: The Use Case Services are actually implemented using the underlying transaction(s) defined by the Profiles or Standards selected. Therefore, the Use Case Services are not depicted directly in the sequence diagrams.

Steps 1 – 10 are related to the directed referral request workflow and are shown in Figure 3.2-12 Transactions associated with directed referral (1).

1. The patient is being provided with ambulatory healthcare. As part of the care the Healthcare Provider or Organization obtained the patient's KSA-Wide Health ID and has access to the patient's medical records. See pre-conditions described in Section 3.2.1 Sequence diagram pre-conditions. Patient records are obtained using the Clinical Content Consumer as defined in the IS0007 *Saudi eHealth Core Interoperability Specification for Clinical Notes and Summaries* document.
2. The Healthcare Provider diagnoses a problem which requires services not offered by the local Healthcare Organization, thus decides to refer the patient to a Healthcare Organization that is able to provide the needed services. The referral Healthcare Organization has a business agreement with a specific receiving Healthcare Organization for such services, therefore performs a directed referral.
3. The Referral Requester/XDW Content Creator/Document Source Actor publishes two documents to the HIE Document Repository [IHE XDS.b: Provide & Register Document Set ITI-41] (see Section 3.2.2.3 Publish Referral/Transfer Document(s) to the HIE Document Repository for the full set of transactions). They are a Referral Request Document and an IHE XDW Document with a Request Referral Task. Inputs to the task include references to relevant patient attached documents and the output of the task is the Referral Request Document. It also creates a Respond to Referral Request Task.
4. The HIE Document Repository stores the document(s) and the notification of document availability is transmitted [IHE DSUB Profile: Document Metadata Notify ITI-53] to the Referral/Transfer Receiver/Notification Recipient that was identified via the IHE XDW Document.
5. The Referral/Transfer Receiver/XDW Content Updater/Document Consumer retrieves the IHE XDW Document, Referral Request Document and attached documents.
6. Upon review of the information, a Healthcare Provider from the Referral/Transfer Receiver decides it needs additional information on the patient before accepting the referral. The Referral/Transfer Receiver/XDW Content Updater/Document Source updates the IHE XDW Document with a Request Information Task. Textual information

is provided to describe what information is being requested (e.g. imaging reports, laboratory tests, etc.) The updated IHE XDW Document is published to the HIE Document Registry.

7. The notification of document availability is transmitted from the HIE Document Repository to the Referral Requester/Notification Recipient [IHE DSUB Profile: Document Metadata Notify ITI-53].
8. The Referral Requester/XDW Content Updater/Document Consumer retrieves the updated IHE XDW Document with the Request Information Task and referenced attached textual information.
9. The Referral Requester/XDW Content Updater/Document Consumer process the IHE XDW Document and updates in the IHE XDW Document the Request Information Task with the referenced additional information attached as part of the output of the task. The updated IHE XDW Document is sent to the HIE Document Repository [IHE XDS.b: Provide & Register Document Set ITI-41].
10. The notification of document availability is transmitted from the HIE Document Repository to the Referral/Transfer Receiver/Notification Recipient Actor [IHE DSUB Profile: Document Metadata Notify ITI-53].

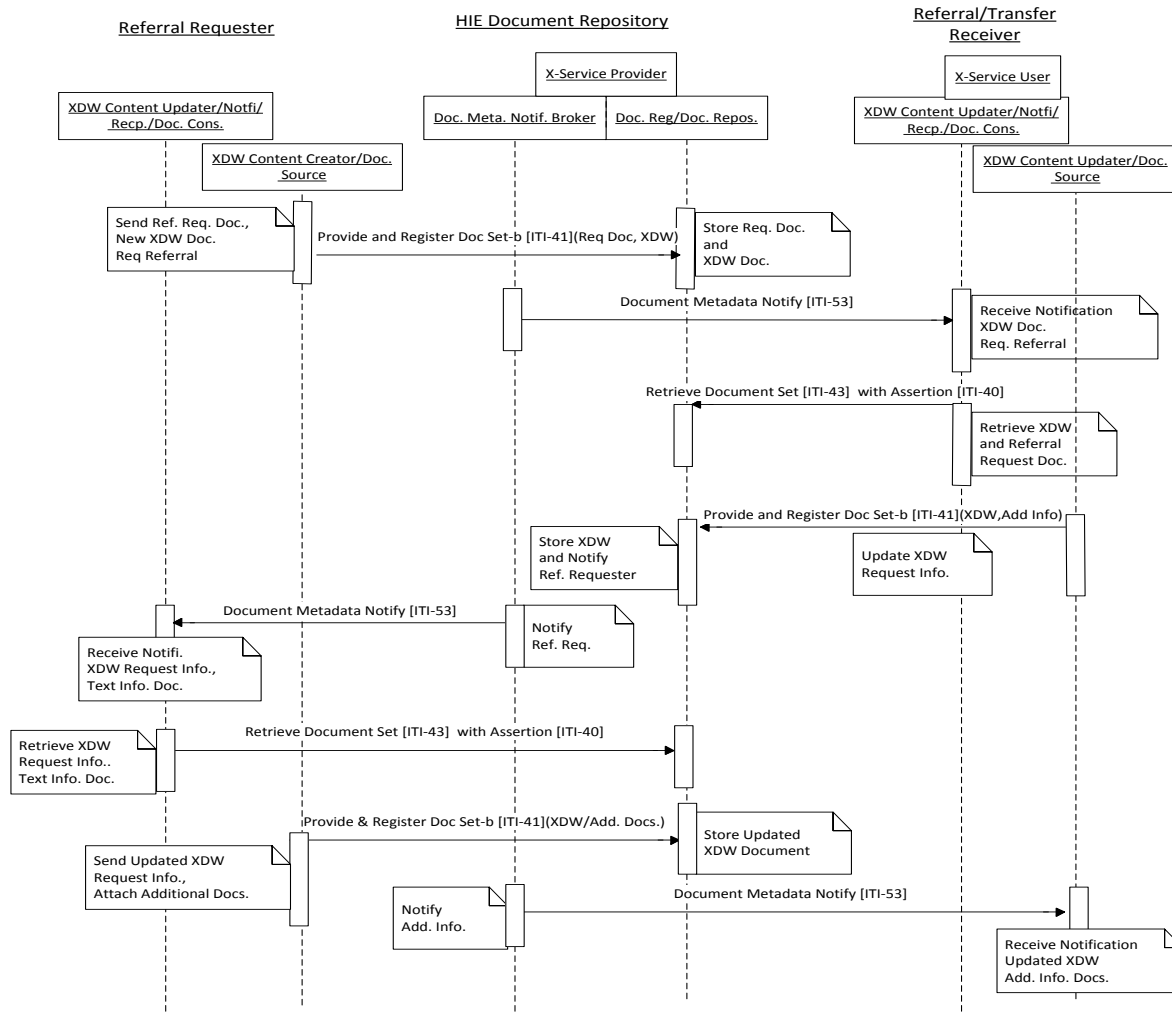

FIGURE 3.2-12 TRANSACTIONS ASSOCIATED WITH DIRECTED REFERRAL (1)

Steps 11 – 23 are related to the directed referral request workflow and are shown in Figure 3.2-3 Transactions associated with directed referral (2).

11. The Referral/Transfer Receiver/XDW Content Updater/Document Consumer retrieves the IHE XDW Document, Referral Request Document and the referenced additional attached documents.
12. The Referral/Transfer Receiver/XDW Content Updater/Document Source Actor evaluates the referral request including the additional information and decides to accept the request. It generates a Referral/Transfer Response Document and updates in the IHE XDW Document the Respond to Referral Request Task. It also creates a Perform Referral Task. The updated IHE XDW Document and Referral/Transfer Response Document is sent to the IHE Document Repository [IHE XDS.b: Provide & Register Document Set ITI-41].



13. The notification of document availability is transmitted from the HIE Document Repository to the Referral Requester/Notification Recipient [IHE DSUB Profile: Document Metadata Notify ITI-53].
14. The Referral Requester/XDW Content Updater/Document Consumer retrieves the updated IHE XDW Document with the Response to Referral Task, Perform Referral Task and Referral/Transfer Response Document.
15. The patient communicates with the Referral/Transfer Receiver organization and an appointment is scheduled (how this is accomplished is outside the scope of the Core Interoperability Specification). The Referral/Transfer Receiver/XDW Content Updater/Document Source Actor updates in the IHE XDW Document the Perform Referral Task and includes the appointment notice information as an input document. The updated IHE XDW Document is sent to the HIE Document Repository [IHE XDS.b: Provide & Register Document Set ITI-41].
16. The notification of document availability is transmitted from the HIE Document Repository to Referral Requester/Notification Recipient Actor [IHE DSUB Profile: Document Metadata Notify ITI-53].
17. The Referral Requester/XDW Content Updater/Document Consumer retrieves the IHE XDW Document from the HIE Document Repository, processes the IHE XDW Document and learns when the appointment is scheduled.
18. The patient arrives as the Referral/Transfer Receiver facility and the Referral/Transfer Receiver/XDW Content Updater/Document Source Actor updates in the IHE XDW Document the Perform Referral Task. The updated IHE XDW Document is sent to the HIE Document Repository [IHE XDS.b: Provide & Register Document Set ITI-41].
19. The notification of document availability is transmitted from the HIE Document Repository to the Referral Requester/Notification Recipient Actor [IHE DSUB Profile: Document Metadata Notify ITI-53].
20. The Referral Requester/XDW Content Updater/Document Consumer retrieves the IHE XDW Document from the HIE Document Repository, processes the IHE XDW Document and learns the patient has arrived at the Referral/Transfer Receiver facility.
21. The service for that patient has been performed and is completed. The Referral/Transfer Receiver/XDW Content Updater/Document Source Actor updates in the IHE XDW Document the Perform Referral Task and references attached documents as the result of performing the referral service. The updated IHE XDW Document is sent to the HIE Document Repository [IHE XDS.b: Provide & Register Document Set ITI-41].
22. The notification of document availability is transmitted from the HIE Document Repository to the Referral Requester/Notification Recipient Actor [IHE DSUB Profile: Document Metadata Notify ITI-53].
23. The Referral Requester/XDW Content Updater/Document Consumer retrieves the IHE XDW Document from the HIE Document Repository, processes the IHE XDW Document and learns the patient's referral has been completed. The Healthcare Provider may also review the referenced attached document to better prepare for future encounters with the patient.

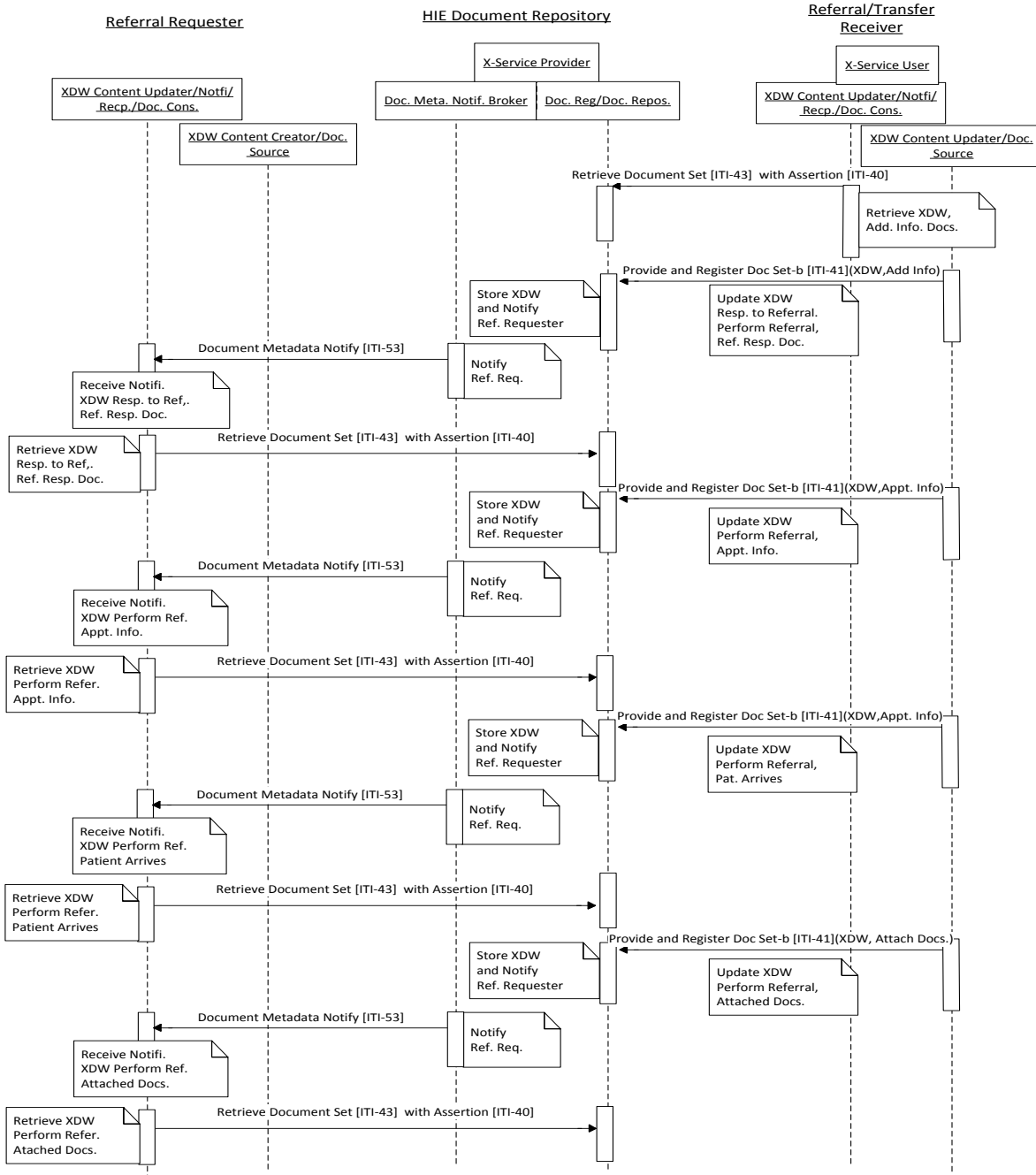

FIGURE 3.2-3 TRANSACTIONS ASSOCIATED WITH DIRECTED REFERRAL (2)

## 4. REFERRAL WORKFLOW ACTOR CONFORMANCE

This section is designed to establish the Conformance Requirements for the Interoperability Specification. It maps one to one, with the table in section **Error! Reference source not found.**

### 4.1 TRANSFER REQUESTER CONFORMANCE

Systems may claim conformance to the IS0011 *Saudi eHealth Core Interoperability Specification for Referral and Transfer Workflow* as a Transfer Requester as follows:

#### Referral and Transfer Workflow -- Transfer Requester Actor

This requires:

- to support the Manage Referral or Transfer Service by conforming to:

[RTW-00025] IHE – Cross-Enterprise Document Sharing Workflow (XDW) Integration Profile as a XDW Content Creator with the additional constraints specified in:

- See Sections 5.1 and 5.2

[RTW-00026] IHE – Cross-Enterprise Document Sharing Workflow (XDW) Integration Profile as a XDW Content Updater with the additional constraints specified in:

See Sections 5.1 and 5.2 [RTW-027] IHE – IT Infrastructure Technical Framework- IHE Scanned Documents (SD) as a Content Creator Actor with the additional constraints specified in:

- IS0106 Saudi eHealth Clinical Documents Constrains Interoperability Specifications – Section 5.11.

[RTW-00028] IHE – Patient Care Coordination Technical Framework as a Content Creator Actor with the additional constraints specified in:

- IS0106 Saudi eHealth Clinical Documents Constrains Interoperability Specifications – Section 5.12.

[RTW-00029] IHE – Cross-Enterprise Document Sharing (XDS.b) Integration Profile as a Document Source Actor with the additional constraints specified in:

- IS0102 *Saudi eHealth Document Sharing Interoperability Specification* – Section 3.2.

[RTW-00030] IHE Audit Trail and Node Authentication (ATNA) Integration Profile as a Secure Node Actor with the additional constraints specified in:

- IS0101 *Saudi eHealth Security and Privacy Interoperability Specification* – Section 3.2 and 3.3.2.

[RTW-00031] IHE Consistent Time (CT) Integration Profile as a Time Client Actor with the additional constraints specified in:

- IS0101 *Saudi eHealth Security and Privacy Interoperability Specification* – Section 3.1.2.

- To support the Query/Retrieve Document(s) Service by conforming to::

[RTW-00032] IHE – Cross-Enterprise Document Sharing Workflow (XDW) Integration Profile as a XDW Content Updater with the additional constraints specified in:

See Sections 5.1 and 5.2 [RTW-00033]- IHE – Cross-Enterprise Document Sharing (XDS.b) Integration Profile as a Document Consumer Actor with the additional constraints specified in:

- See IS0102 *Saudi eHealth Document Sharing Interoperability – Section 3.3.*

[RTW-00034] IHE – IT Infrastructure Technical Framework- IHE Scanned Documents (SD) as a Content Consumer Actor with the additional constraints specified in:

- IS0106 Saudi eHealth Clinical Documents Constrains Interoperability Specifications – Section 5.11.

[RTW-00035] IHE – Patient Care Coordination Technical Framework as a Content Consumer Actor with the additional constraints specified in:

- IS0106 Saudi eHealth Clinical Documents Constrains Interoperability Specifications – Section 5.12.

[RTW-00036] IHE – Patient Care Coordination Technical Framework as a Content Consumer Actor with the additional constraints specified in:

- IS0106 Saudi eHealth Clinical Documents Constrains Interoperability Specifications – Section 5.13.

[RTW-00037] IHE – Cross-Enterprise User Assertion (XUA) Integration Profile as an X-Service User Actor with the additional constraints specified in:

- IS0101 *Saudi eHealth Security and Privacy Interoperability Specification – Section 3.4.1.*

[RTW-00038] IHE Audit Trail and Node Authentication (ATNA) Integration Profile as a Secure Node Actor with the additional constraints specified in:

- IS0101 *Saudi eHealth Security and Privacy Interoperability Specification – Sections 3.2 and 3.3.2.*

[RTW-00039] IHE Consistent Time (CT) Integration Profile as a Time Client Actor with the additional constraints specified in:

- IS0101 *Saudi eHealth Security and Privacy Interoperability Specification – Section 3.1.2.*

- To support the Notification of Document Availability Service by conforming to:

[RTW-00040] IHE - Document Metadata Subscription (DSUB) Integration Profile as a Document Metadata Notification Recipient Actor with the additional constraints specified in

- IS0102 *Saudi eHealth Document Sharing Interoperability Specification - Section 4.2.*

[RTW-00041] IHE Audit Trail and Node Authentication (ATNA) Integration Profile as a Secure Node Actor with the additional constraints specified in:

- IS0101 *Saudi eHealth Security and Privacy Interoperability Specification* – Sections 3.2 and 3.3.2.

[RTW-00042] IHE Consistent Time (CT) Integration Profile as a Time Client Actor with the additional constraints specified in:

- IS0101 *Saudi eHealth Security and Privacy Interoperability Specification* – Section 3.1.2.

## 4.2 REFERRAL REQUESTER CONFORMANCE

Systems may claim conformance to the IS0011 *Saudi eHealth Core Interoperability Specification for Referral and Transfer Workflow* as a Referral Requester as follows:

### Referral and Transfer Workflow -- Referral Requester Actor

This requires:

- to support the Manage Referral or Transfer Service by conforming to:

[RTW-00001] IHE – Cross-Enterprise Document Sharing Workflow (XDW) Integration Profile as a XDW Content Creator with the additional constraints specified in:

See Sections 5.1 and 5.3 [RTW-00002] IHE – Cross-Enterprise Document Sharing Workflow (XDW) Integration Profile as a XDW Content Updater with the additional constraints specified in:

- See Sections 5.1 and 5.3.

[RTW-00003] IHE – IT Infrastructure Technical Framework- IHE Scanned Documents (SD) as a Content Creator Actor with the additional constraints specified in:

- IS0106 *Saudi eHealth Clinical Documents Constrains Interoperability Specifications* – Section 5.11.

[RTW-00004] IHE – Patient Care Coordination Technical Framework as a Content Creator Actor with the additional constraints specified in:

- IS0106 *Saudi eHealth Clinical Documents Constrains Interoperability Specifications* – Section 5.12.

[RTW-00005] IHE – Cross-Enterprise Document Sharing (XDS.b) Integration Profile as a Document Source Actor with the additional constraints specified in:

- IS0102 *Saudi eHealth Document Sharing Interoperability Specification* – Section 3.2.

[RTW-00006] IHE Audit Trail and Node Authentication (ATNA) Integration Profile as a Secure Node Actor with the additional constraints specified in:

- IS0101 *Saudi eHealth Security and Privacy Interoperability Specification* – Section 3.2 and 3.3.2.

[RTW-00007] IHE Consistent Time (CT) Integration Profile as a Time Client Actor with the additional constraints specified in:

- IS0101 *Saudi eHealth Security and Privacy Interoperability Specification – Section 3.1.2.*

➤ To support the Query/Retrieve Document(s) Service by conforming to:

[RTW-00008] IHE – Cross-Enterprise Document Sharing Workflow (XDW) Integration Profile as a XDW Content Updater with the additional constraints specified in:

- See Sections 5.1 and 5.3.

[RTW-00009] IHE – Cross-Enterprise Document Sharing (XDS.b) Integration Profile as a Document Consumer Actor with the additional constraints specified in:

- See IS0102 *Saudi eHealth Document Sharing Interoperability Specification – Section 3.3.*

[RTW-00010] IHE – IT Infrastructure Technical Framework- IHE Scanned Documents (SD) as a Content Consumer Actor with the additional constraints specified in:

- IS0106 *Saudi eHealth Clinical Documents Constrains Interoperability Specifications – Section 5.11.*

[RTW-00011] IHE – Patient Care Coordination Technical Framework as a Content Consumer Actor with the additional constraints specified in:

- IS0106 *Saudi eHealth Clinical Documents Constrains Interoperability Specifications – Section 5.12.*

[RTW-00012] IHE – Patient Care Coordination Technical Framework as a Content Consumer Actor with the additional constraints specified in:

- IS0106 *Saudi eHealth Clinical Documents Constrains Interoperability Specifications – Section 5.13.*

[RTW-00013] Internet Calendaring and Scheduling Core Object Specification (iCalendar) RFC 5545 as a Content Consumer Actor with the additional constraints specified in:

- See Section 5.1.2.

[RTW-00014] IHE – Cross-Enterprise User Assertion (XUA) Integration Profile as an X-Service User Actor with the additional constraints specified in:

- IS0101 *Saudi eHealth Security and Privacy Interoperability Specification – Section 3.4.1.*

[RTW-00015] IHE Audit Trail and Node Authentication (ATNA) Integration Profile as a Secure Node Actor with the additional constraints specified in:

- IS0101 *Saudi eHealth Security and Privacy Interoperability Specification – Sections 3.2 and 3.3.2.*

[RTW-00016] IHE Consistent Time (CT) Integration Profile as a Time Client Actor with the additional constraints specified in:

- IS0101 *Saudi eHealth Security and Privacy Interoperability Specification* – Section 3.1.2.

➤ To support the Notification of Document Availability Service by conforming to:

[RTW-00017] IHE - Document Metadata Subscription (DSUB) Integration Profile as a Document Metadata Notification Recipient Actor with the additional constraints specified in

- IS0102 *Saudi eHealth Document Sharing Interoperability Specification* - Section 4.2

[RTW-00018] IHE Audit Trail and Node Authentication (ATNA) Integration Profile as a Secure Node Actor with the additional constraints specified in:

- IS0101 *Saudi eHealth Security and Privacy Interoperability Specification* – Sections 3.2 and 3.3.2.

[RTW-00019] IHE Consistent Time (CT) Integration Profile as a Time Client Actor with the additional constraints specified in:

- IS0101 *Saudi eHealth Security and Privacy Interoperability Specification* – Section 3.1.2.

### **4.3 WORKFLOW MANAGER CONFORMANCE**

Systems may claim conformance to the IS0011 *Saudi eHealth Core Interoperability Specification for Referral and Transfer Workflow* as a Workflow Manager as follows:

#### **Referral and Transfer Workflow -- Workflow Manager Actor**

This requires:

➤ to support the Manage Referral or Transfer Service by conforming to:

[RTW-00045] IHE – Cross-Enterprise Document Sharing Workflow (XDW) Integration Profile as a XDW Content Updater with the additional constraints specified in:

- See Sections 5.1 and 5.4.

[RTW-00046] IHE – Cross-Enterprise Document Sharing (XDS.b) Integration Profile as a Document Source Actor with the additional constraints specified in:

- IS0102 *Saudi eHealth Document Sharing Interoperability Specification* – Section 3.2.

[RTW-00047] IHE – Patient Care Coordination Technical Framework as a Content Creator Actor with the additional constraints specified in:

- IS0106 *Saudi eHealth Clinical Documents Constrains Interoperability Specifications* – Section 5.13.

[RTW-00048] IHE Audit Trail and Node Authentication (ATNA) Integration Profile as a Secure Node Actor with the additional constraints specified in:

- IS0101 *Saudi eHealth Security and Privacy Interoperability Specification* – Section 3.2 and 3.3.2.

[RTW-00049] IHE Consistent Time (CT) Integration Profile as a Time Client Actor with the additional constraints specified in:

- IS0101 *Saudi eHealth Security and Privacy Interoperability Specification* – Section 3.1.2.

➤ To support the Query/Retrieve Document(s) Service by conforming to::

[RTW-00050] IHE – Cross-Enterprise Document Sharing Workflow (XDW) Integration Profile as a XDW Content Updater with the additional constraints specified in:

- See Sections 5.1 and 5.4.

[RTW-00051]- IHE – Cross-Enterprise Document Sharing (XDS.b) Integration Profile as a Document Consumer Actor with the additional constraints specified in:

- See IS0102 *Saudi eHealth Document Sharing Interoperability Specification* – Section 3.3.

[RTW-00052] IHE – IT Infrastructure Technical Framework- IHE Scanned Documents (SD) as a Content Consumer Actor with the additional constraints specified in:

- IS0106 *Saudi eHealth Clinical Documents Constrains Interoperability Specifications* – Section 5.11.

[RTW-00053] IHE – Patient Care Coordination Technical Framework as a Content Consumer Actor with the additional constraints specified in:

- IS0106 *Saudi eHealth Clinical Documents Constrains Interoperability Specifications* – Section 5.12.

[RTW-00054] IHE – Patient Care Coordination Technical Framework as a Content Consumer Actor with the additional constraints specified in:

- IS0106 *Saudi eHealth Clinical Documents Constrains Interoperability Specifications* – Section 5.13.

[RTW-00055] Internet Calendaring and Scheduling Core Object Specification (iCalendar) RFC 5545 as a Content Consumer Actor with the additional constraints specified in:

- See Section 5.1.2.

[RTW-00056] IHE – Cross-Enterprise User Assertion (XUA) Integration Profile as an X-Service User Actor with the additional constraints specified in:

- IS0101 *Saudi eHealth Security and Privacy Interoperability Specification* – Section 3.4.1.



[RTW-00057] IHE Audit Trail and Node Authentication (ATNA) Integration Profile as a Secure Node Actor with the additional constraints specified in:

- IS0101 *Saudi eHealth Security and Privacy Interoperability Specification* – Sections 3.2 and 3.3.2.

[RTW-00058] IHE Consistent Time (CT) Integration Profile as a Time Client Actor with the additional constraints specified in:

- IS0101 *Saudi eHealth Security and Privacy Interoperability Specification* – Section 3.1.2.

➤ To support the Notification of Document Availability Service by conforming to:

[RTW-00059] IHE - Document Metadata Subscription (DSUB) Integration Profile as a Document Metadata Notification Recipient Actor with the additional constraints specified in

- IS0102 *Saudi eHealth Document Sharing Interoperability Specification* - Section 4.2.

[RTW-00060] IHE Audit Trail and Node Authentication (ATNA) Integration Profile as a Secure Node Actor with the additional constraints specified in:

- IS0101 *Saudi eHealth Security and Privacy Interoperability Specification* – Sections 3.2 and 3.3.2.

[RTW-00061] IHE Consistent Time (CT) Integration Profile as a Time Client Actor with the additional constraints specified in:

- IS0101 *Saudi eHealth Security and Privacy Interoperability Specification* – Section 3.1.2.

#### **4.4 REFERRAL/TRANSFER RECEIVER CONFORMANCE**

Systems may claim conformance to the IS0011 *Saudi eHealth Core Interoperability Specification for eReferral and eTransfer Workflow* as a Referral/Transfer Receiver as follows:

##### Referral and Transfer Workflow -- Referral/Transfer Receiver Actor

This requires:

➤ to support the Manage Referral or Transfer Service by conforming to:

[RTW-00065] IHE – Cross-Enterprise Document Sharing Workflow (XDW) Integration Profile as a XDW Content Updater with the additional constraints specified in:

- See Sections 5.1 and 5.5.

[RTW-00066] IHE – IT Infrastructure Technical Framework- IHE Scanned Documents (SD) as a Content Creator Actor with the additional constraints specified in:

- IS0106 *Saudi eHealth Clinical Documents Constrains Interoperability Specifications* – Section 5.11.

[RTW-00067] IHE – Patient Care Coordination Technical Framework as a Content Creator Actor with the additional constraints specified in:

- IS0106 Saudi eHealth Clinical Documents Constrains Interoperability Specifications – Section 5.13.

[RTW-00068] Internet Calendaring and Scheduling Core Object Specification (iCalendar) RFC 5545 as a Content Creator Actor with the additional constraints specified in:

- See Section 5.1.2.

[RTW-00069] IHE – Cross-Enterprise Document Sharing (XDS.b) Integration Profile as a Document Source Actor with the additional constraints specified in:

- IS0102 *Saudi eHealth Document Sharing Interoperability Specification* – Section 3.2.

[RTW-00070] IHE Audit Trail and Node Authentication (ATNA) Integration Profile as a Secure Node Actor with the additional constraints specified in:

- IS0101 *Saudi eHealth Security and Privacy Interoperability Specification* – Section 3.2 and 3.3.2.

[RTW-00071] IHE Consistent Time (CT) Integration Profile as a Time Client Actor with the additional constraints specified in:

- IS0101 *Saudi eHealth Security and Privacy Interoperability Specification* – Section 3.1.2.

➤ To support the Query/Retrieve Document(s) Service by conforming to::

[RTW-00072] IHE – Cross-Enterprise Document Sharing Workflow (XDW) Integration Profile as a XDW Content Updater with the additional constraints specified in:

- See Sections 5.1 and 5.5.

[RTW-00073]- IHE – Cross-Enterprise Document Sharing (XDS.b) Integration Profile as a Document Consumer Actor with the additional constraints specified in:

- See IS0102 *Saudi eHealth Document Sharing Interoperability Specification* – Section 3.3.

[RTW-00074] IHE – IT Infrastructure Technical Framework- IHE Scanned Documents (SD) as a Content Consumer Actor with the additional constraints specified in:

- IS0106 Saudi eHealth Clinical Documents Constrains Interoperability Specifications – Section 5.11.

[RTW-00075] IHE – Patient Care Coordination Technical Framework as a Content Consumer Actor with the additional constraints specified in:

- IS0106 Saudi eHealth Clinical Documents Constrains Interoperability Specifications – Section 5.12.

[RTW-00076] IHE – Patient Care Coordination Technical Framework as a Content Consumer Actor with the additional constraints specified in:

- IS0106 Saudi eHealth Clinical Documents Constrains Interoperability Specifications – Section 5.13.

[RTW-00077] Internet Calendaring and Scheduling Core Object Specification (iCalendar) RFC 5545 as a Content Consumer Actor with the additional constraints specified in:

- See Section 5.1.2.

[RTW-00078] IHE – Cross-Enterprise User Assertion (XUA) Integration Profile as an X-Service User Actor with the additional constraints specified in:

- IS0101 *Saudi eHealth Security and Privacy Interoperability Specification* – Section 3.4.1.

[RTW-00079] IHE Audit Trail and Node Authentication (ATNA) Integration Profile as a Secure Node Actor with the additional constraints specified in:

- IS0101 *Saudi eHealth Security and Privacy Interoperability Specification* – Sections 3.2 and 3.3.2.

[RTW-00080] IHE Consistent Time (CT) Integration Profile as a Time Client Actor with the additional constraints specified in:

- IS0101 *Saudi eHealth Security and Privacy Interoperability Specification* – Section 3.1.2.

➤ To support the Notification of Document Availability Service by conforming to:

[RTW-00081] IHE - Document Metadata Subscription (DSUB) Integration Profile as a Document Metadata Notification Recipient Actor with the additional constraints specified in

- IS0102 *Saudi eHealth Document Sharing Interoperability Specification* - Section 4.2.

[RTW-00082] IHE Audit Trail and Node Authentication (ATNA) Integration Profile as a Secure Node Actor with the additional constraints specified in:

- IS0101 *Saudi eHealth Security and Privacy Interoperability Specification* – Sections 3.2.

[RTW-00083] IHE Consistent Time (CT) Integration Profile as a Time Client Actor with the additional constraints specified in:

- IS0101 *Saudi eHealth Security and Privacy Interoperability Specification* – Section 3.1.2.

#### **4.5 HIE DOCUMENT REPOSITORY CONFORMANCE**

Systems may claim conformance to the IS0011 *Saudi eHealth Core Interoperability Specification for Referral and Transfer Workflow* as a HIE Document Repository as follows:

Referral and Transfer Workflow -- HIE Document Repository Actor

This requires:

- To support the Publish Document(s) Service by conforming to:

[RTW-00085]- IHE Cross-Enterprise Document Sharing (XDS.b) Integration Profile as a Document Repository with the additional constraints specified in:

- IS0102 *Saudi eHealth Document Sharing Interoperability Specification* – Section 3.4.

[RTW-00086] IHE Audit Trail and Node Authentication (ATNA) Integration Profile as a Secure Node Actor with the additional constraints specified in:

- IS0101 *Saudi eHealth Security and Privacy Interoperability Specification* – Section 3.2 and 3.3.1.

[RTW00-087] IHE Consistent Time (CT) Integration Profile as a Time Client Actor with the additional constraints specified in:

- IS0101 *Saudi eHealth Security and Privacy Interoperability Specification* – Section 3.1.2.

- To support the Query/Retrieve Document(s) Service by conforming to:

[RTW-00088]- IHE Cross-Enterprise Document Sharing (XDS.b) Integration Profile as a Document Registry and Document Repository Actor with the additional constraints specified in:

- IS0102 *Saudi eHealth Document Sharing Interoperability Specification* – Section 3.4.

[RTW-00089] IHE Cross-Enterprise User Assertion (XUA) Integration Profile as an X-Service Provider Actor with the additional constraints specified in:

- IS0101 *Saudi eHealth Security and Privacy Interoperability Specification* – Section 3.4.2.

[RTW-00090] IHE Audit Trail and Node Authentication (ATNA) Integration Profile as a Secure Node Actor with the additional constraints specified in:

- IS0101 *Saudi eHealth Security and Privacy Interoperability Specification* – Section 3.2 and 3.3.1.

[RTW-00091] IHE Consistent Time (CT) Integration Profile as a Time Client Actor with the additional constraints specified in:

- IS0101 *Saudi eHealth Security and Privacy Interoperability Specification* – Section 3.1.2.

- To support the Notification of Document Availability Service by conforming to:

[RTW-00092] IHE Document Metadata Subscription (DSUB) Integration Profile as a Document Metadata Notification Broker Actor with the additional constraints specified in:

- IS0102 *Saudi eHealth Document Sharing Interoperability Specification* - Section 4.1.

[RTW-00093] IHE Audit Trail and Node Authentication (ATNA) Integration Profile as a Secure Node Actor with the additional constraints specified in:

- IS0101 *Saudi eHealth Security and Privacy Interoperability Specification* – Section 3.2 and 3.3.1.

[RTW-00094] IHE Consistent Time (CT) Integration Profile as a Time Client Actor with the additional constraints specified in:

- IS0101 *Saudi eHealth Security and Privacy Interoperability Specification* – Section 3.1.2.

## 5. SAUDI EHEALTH CONSTRAINTS ON THE REFERRAL WORKFLOW

This section defines required behavior rules for Use Case Actors defined in this Core Interoperability Specification.

### 5.1 GENERAL WORKFLOW PARTICIPANT ACTOR RESPONSIBILITIES

All General Workflow Participants:

[RTW-00101] **SHALL** include all new Input Documents or Output Documents in the Submission Set in the Provide and Register Transaction for each task created or updated.

[RTW-00102] **SHALL** set the **referenceldList** metadata to the identifier of the first task created or updated in the workflow document.

This must be the task whose most recent task event has the earliest **lastModification** date. This will allow receivers of a document notification event on creation or update of a workflow document to determine what workflow actions occurred since the workflow was previously updated by inspecting the task event history for every even occurring on or after the date of last modification of the earliest task to be altered.

[RTW-00103] **SHALL** set the **intendedRecipient** metadata in the Provide a Register Transaction to all workflow participants that initiated, own or are to be notified on changes of a task.

Note: This can be determined by inspection of the <actualOwner>, <taskInitiator> and <notificationRecipients> elements in the <taskDetail> element of the task history in the workflow document.

[RTW-00104] **SHALL** be configurable with the notification identifier(s) for any Workflow Manager associated with the Collaboration Circles from which it can request services or provide services.

#### 5.1.1 Workflow Identifiers

[RTW-00111] **SHALL** identify instances of the Transfer Workflow with the identifier 2.16.840.1.113883.3731.1.11.1 in workflow documents.

[RTW-00112] **SHALL** identify instances of the Referral Workflow with the identifier 2.16.840.1.113883.3731.1.11.2 in workflow documents.

[RTW-00113] **SHALL** identify instances of the Direct Transfer Workflow with the identifier 2.16.840.1.113883.3731.1.11.3 in workflow documents.

[RTW-00114] **SHALL** identify instances of the Direct Referral Workflow with the identifier 2.16.840.1.113883.3731.1.11.4 in workflow documents.

[RTW-00115] **SHALL** identify instances of the Flexible Referral Workflow with the identifier 2.16.840.1.113883.3731.1.11.5 in workflow documents.

### 5.1.2 Document Metadata and Conformance Requirements

[RTW-00210] **SHALL** ensure that any **Appointment Document** the actor adds as input or output documents to a task conforms to the requirements found in *RFC 5545*.

In the **Workflow Document**:

[RTW-00215] **SHALL** use "Appointment Document" as the document label for the **Appointment Document**.

The XDS Metadata Attributes of these referenced documents must be set as follows:

[RTW-00216] The `title` attribute **SHALL** be set to "Appointment Document".

[RTW-00211] The `classCode` attribute **SHALL** be set to "WORKFLOWS" from the "*KSA Class Code*" Value Set.

[RTW-00212] The `typeCode` attribute **SHALL** be set to "AppointmentDocument" from the "*KSA Referral and Transfer Document Type*" Value Set.

[RTW-00213] The `contentType` attribute **SHALL** be set to "text/calendar" from the "*MIME Type*" Value Set.

[RTW-00214] The `formatCode` attribute **SHALL** be set to "urn:ietf:rftc5545" from the "*KSA Format Code*" Value Set.

[RTW-00220] **SHALL** ensure that any **Information Request Document** the actor adds as input or output documents to a task conform to the requirements found in *Section 5.11 Scanned Documents in IS0106 Saudi eHealth Clinical Documents Constrains Interoperability Specifications*.

In the **Workflow Document**:

[RTW-00225] **SHALL** use "Information Request Document" as the document label in the workflow document.

In the **Information Request Document**:

[RTW-00227] **SHALL** set `/ClinicalDocument/code` to "InformationRequestDocument" KSA Referral and Transfer Document Type.

[RTW-00228] **SHALL** set `/ClinicalDocument/title` to "Information Request Document".

For the **Information Request Document**:

The XDS Metadata Attributes of these referenced documents must be set as follows:

[RTW-00226] The `title` attribute **SHALL** be set to "Information Request Document".

[RTW-00221] The `classCode` attribute **SHALL** be set to "WORKFLOWS" from the "*KSA Class Code*" Value Set.

[RTW-00222] The `typeCode` attribute **SHALL** be set to "InformationRequestDocument" from the "*KSA Referral and Transfer Document Type*" Value Set.

[RTW-00223] The `contentType` attribute **SHALL** be set to "text/xml" from the "*MIME Type*" Value Set.

[RTW-00224] The `formatCode` attribute **SHALL** be set to "urn:ihe:iti:xds-sd:text:2008" from the "*KSA Format Code*" Value Set.

[RTW-00230] **SHALL** ensure that any **Information Response Document** the actor adds as input or output documents to a task conform to the requirements found in *Section 5.11 Scanned Documents in IS0106 Saudi eHealth Clinical Documents Constrains Interoperability Specifications*.

In the **Workflow Document**:

[RTW-00235] **SHALL** use "Information Response Document" as the document label in the workflow document.

In the **Information Response Document**:

[RTW-00237] **SHALL** set `/ClinicalDocument/code` to "InformationResponseDocument" KSA Referral and Transfer Document Type.

[RTW-00238] **SHALL** set `/ClinicalDocument/title` to "Information Response Document".

The XDS Metadata Attributes of these referenced documents must be set as follows:

[RTW-00236] The `title` attribute **SHALL** be set to "Information Response Document".

[RTW-00231] The `classCode` attribute **SHALL** be set to "WORKFLOWS" from the "*KSA Class Code*" Value Set.

[RTW-00232] The `typeCode` attribute **SHALL** be set to "InformationResponseDocument" from the "*KSA Referral and Transfer Document Type*" Value Set.

[RTW-00233] The `contentType` attribute **SHALL** be set to "text/xml" from the "*MIME Type*" Value Set.

[RTW-00234] The `formatCode` attribute **SHALL** be set to "urn:ihe:iti:xds-sd:text:2008" from the "*KSA Format Code*" Value Set.

[RTW-00240] **SHALL** ensure that any **Referral Request Document** the actor adds as input or output documents to a task conform to the requirements found in *Section 5.12 HL7 CDA Constraints for Referral Request and Transfer Request Documents in IS0106 Saudi eHealth Clinical Documents Constrains Interoperability Specifications*.

In the **Workflow Document**:

[RTW-00245] **SHALL** use "Referral/Transfer Request Document" as the document label in the workflow document.

The XDS Metadata Attributes of these referenced documents must be set as follows:

[RTW-00246] The `title` attribute **SHALL** be set to "Referral Request Document".

[RTW-00241] The `classCode` attribute **SHALL** be set to "WORKFLOWS" from the "*KSA Class Code*" Value Set.

[RTW-00242] The `typeCode` attribute **SHALL** be set to "ReferralRequestDocument" from the "*KSA Referral and Transfer Document Type*" Value Set.

[RTW-00243] The `contentType` attribute **SHALL** be set to "text/xml" from the "*MIME Type*" Value Set.

[RTW-00244] The `formatCode` attribute **SHALL** be set to "urn:ksa-ehealth:cda:rtw-request:2014" from the "*KSA Format Code*" Value Set.



[RTW-00250] **SHALL** ensure that any **Transfer Request Document** the actor adds as input or output documents to a task conform to the requirements found in *Section 5.12 HL7 CDA Constraints for Referral Request and Transfer Request in IS0106 Saudi eHealth Clinical Documents Constrains Interoperability Specifications*.

In the **Workflow Document**:

[RTW-00255] **SHALL** use "Referral/Transfer Request Document" as the document label in the workflow document.

The XDS Metadata Attributes of these referenced documents must be set as follows:

[RTW-00256] The `title` attribute **SHALL** be set to "Referral/Transfer Request Document".

[RTW-00251] The `classCode` attribute **SHALL** be set to "WORKFLOWS" from the "***KSA Class Code***" Value Set.

[RTW-00252] The `typeCode` attribute **SHALL** be set to "TransferRequestDocument" from the "***KSA Referral and Transfer Document Type***" Value Set.

[RTW-00253] The `mimeType` attribute **SHALL** be set to "text/xml" from the "***MIME Type***" Value Set.

[RTW-00254] The `formatCode` attribute **SHALL** be set to "urn:ksa-ehealth:cda:rtw-request:2014" from the "***KSA Format Code***" Value Set.

[RTW-00270] **SHALL** ensure that any **Referral/Transfer Response Document** the actor adds as input or output documents to a task conform to the requirements found in *Section 5.13 Referral/Transfer Response Document in IS0106 Saudi eHealth Clinical Documents Constrains Interoperability Specifications*.

In the **Workflow Document**:

[RTW-00275] **SHALL** use "Referral/Transfer Response Document" as the document label in the workflow document.

The XDS Metadata Attributes of these referenced documents must be set as follows:

[RTW-00276] The `title` attribute **SHALL** be set to "Referral/Transfer Response Document".

[RTW-00271] The `classCode` attribute **SHALL** be set to "WORKFLOWS" from the "***KSA Class Code***" Value Set.

[RTW-00272] The `typeCode` attribute **SHALL** be set to "ReferralTransferResponseDocument" from the "***KSA Referral and Transfer Document Type***" Value Set.

[RTW-00273] The `mimeType` attribute **SHALL** be set to "text/xml" from the "***MIME Type***" Value Set.

[RTW-00274] The `formatCode` attribute **SHALL** be set to "urn:ksa-ehealth:cda:rtw-response:2014" from the "***KSA Format Code***" Value Set.

[RTW-00280] **SHALL** ensure that any **Referral Result Document** the actor adds as input or output documents to a task conform to the requirements found in *IS0106 Saudi eHealth Clinical Documents Constrains Interoperability Specifications*.

In the **Workflow Document**:

[RTW-00285] **SHALL** use "Referral Result Document" as the document label in the workflow document.

For the XDS Metadata Attributes of these referenced documents, they must be consistent with the sharing of those documents as specified in other Saudi eHealth Interoperability Specifications. This means that:

[RTW-00281] The `classCode` attribute **SHALL** be set to a value from the “**KSA Class Code**” Value Set.

[RTW-00282] The `typeCode` attribute **SHALL** be set to a value from the “**KSA Document Type**” Value Set.

[RTW-00283] The `mimeType` attribute **SHALL** be set to "text/xml" from the “**MIME Type**” Value Set.

[RTW-00284] The `formatCode` attribute **SHALL** be set to a value from the “**KSA Format Code**” Value Set.

[RTW-00290] **SHALL** ensure that any **Relevant Clinical Document** the actor adds as input or output documents to a task conform to the requirements found in *IS0106 Saudi eHealth Clinical Documents Constrains Interoperability Specifications*.

In the **Workflow Document**:

[RTW-00295] **SHALL** use "Relevant Clinical Document" as the document label for these referenced documents in the workflow document.

For the XDS Metadata Attributes of these referenced documents, they must be consistent with the sharing of those documents as specified in other Saudi eHealth Interoperability Specifications. This means that:

[RTW-00291] The `classCode` attribute **SHALL** be set to the value from the “**KSA Class Code**” Value Set.

[RTW-00292] The `typeCode` attribute **SHALL** be set to a value from the “**KSA Document Type**” Value Set.

[RTW-00293] The `mimeType` attribute **SHALL** be set to "text/xml" from the “**MIME Type**” Value Set.

[RTW-00294] The `formatCode` **SHALL** be set to a value from the “**KSA Format Code**” Value Set.

[RTW-00300] **SHALL** ensure that any **Workflow Document** the actor adds as input or output documents to a task conform to the requirements found in *IS0011 Saudi eHealth Referral and Transfer Workflow Core IS*.

In the **Workflow Document**:

[RTW-00305] **SHALL** use "Workflow Document" as the document label in the workflow document.

The XDS Metadata Attributes of these referenced documents must be set as follows:

[RTW-00306] The `title` attribute **SHALL** be set to "Workflow Document".

[RTW-00301] The `classCode` attribute **SHALL** be set to "WORKFLOWS" from the “**KSA Class Code**” Value Set.

[RTW-00302] The `typeCode` attribute **SHALL** be set to "WorkflowDocument".

[RTW-00303] The `mimeType` attribute **SHALL** be set to "text/xml" from the "***MIME Type***" Value Set.

[RTW-00304] The `formatCode` attribute **SHALL** be set to "urn:ihe:iti:xdw:2011:workflowDoc" from the "***KSA Format Code***" Value Set.

## 5.2 TRANSFER REQUESTER

### 5.2.1 General Requirements

- [RTW-10001] None

### 5.2.2 In the Transfer Workflow:

1. When the patient needs a transfer :

[RTW-10010] The Transfer Requester **SHALL** create a new Request Transfer Task in the COMPLETED state.

[RTW-10011] **SHALL** add **Relevant Clinical documents** to the **Input Documents** for task.

[RTW-10012] **SHALL** add **Transfer Request Document** to the **Output Documents** for task.

[RTW-10015] **SHALL** set the `<actualOwner>` element of the `<taskDetails>` element to the notification identifier for the Transfer Requester actor.

[RTW-10016] **SHALL** set the `<notificationRecipients>` element of the `<taskDetails>` element the notification identifier for the Workflow Manager actor.

2. When the Request Information Task reaches the READY state :

[RTW-10810] The Transfer Requester **SHALL** transition the Request Information Task to the COMPLETED state.

[RTW-10811] **SHALL** add **Information Response Document AND/OR Relevant Clinical Documents** to the **Output Documents** for task.

3. When the Perform Transfer Task reaches the READY state :
  - a. If patient transport is initiated

[RTW-11460] The Transfer Requester **SHALL** transition the Perform Transfer Task to the IN\_PROGRESS state.

[RTW-11461] **SHALL** add **Appointment Document** to the **Input Documents** for task.

[RTW-11462] **SHALL** add **Transfer Request Document** to the **Input Documents** for task.

[RTW-11463] **SHALL** add **Referral/Transfer Response Document** to the **Output Documents** for task.

- b. Otherwise if patient transport is not initiated

[RTW-11510] The Transfer Requester **SHALL** transition the Perform Transfer Task to the FAILURE state.

[RTW-11511] **SHALL** add **Referral/Transfer Response Document** to the **Output Documents** for task.

[RTW-11517] **SHALL** mark the workflow as CLOSED.

### 5.2.3 In the Direct Transfer Workflow:

1. When the patient needs a transfer :

[RTW-11010] The Transfer Requester **SHALL** create a new Request Transfer Task in the COMPLETED state.

[RTW-11011] **SHALL** add **Relevant Clinical documents** to the **Input Documents** for task.

[RTW-11012] **SHALL** add **Transfer Request Document** to the **Output Documents** for task.

[RTW-11015] **SHALL** set the <actualOwner> element of the <taskDetails> element to the notification identifier for the Transfer Requester actor.

[RTW-11016] **SHALL** set the <notificationRecipients> element of the <taskDetails> element to the notification identifier for the Workflow Manager actor.

[RTW-11020] The Transfer Requester **SHALL** create a new Respond to a Transfer Request Task in the READY state.

[RTW-11021] **SHALL** add **Transfer Request Document** to the **Input Documents** for task.

[RTW-11022] **SHALL** add **Relevant Clinical documents** to the **Input Documents** for task.

[RTW-11024] **SHALL** set the <taskInitiator> element of the <taskDetails> element to the notification identifier for the Transfer Requester actor.

[RTW-11025] **SHALL** set the <actualOwner> element of the <taskDetails> element to the notification identifier for the Referral/Transfer Receiver actor.

[RTW-11026] **SHALL** set the <notificationRecipients> element of the <taskDetails> element to the notification identifier for the Workflow Manager actor.

2. When the Request Information Task reaches the READY state :

[RTW-11410] The Transfer Requester **SHALL** transition the Request Information Task to the COMPLETED state.

[RTW-11411] **SHALL** add **Information Response Document AND/OR Relevant Clinical Documents** to the **Output Documents** for task.

3. When the Respond to a Transfer Request Task reaches the COMPLETED state or timeout on response :
  - a. If acceptable response is received

[RTW-11660] The Transfer Requester **SHALL** create a new Perform Transfer Task in the READY state.

[RTW-11661] **SHALL** add **Referral/Transfer Response Document** to the **Output Documents** for task.

[RTW-11664] **SHALL** set the <taskInitiator> element of the <taskDetails> element to the notification identifier for the Transfer Requester actor.

[RTW-11665] **SHALL** set the <actualOwner> element of the <taskDetails> element to the notification identifier for the Referral/Transfer Receiver actor.

[RTW-11666] **SHALL** set the <notificationRecipients> element of the <taskDetails> element to the notification identifier for the Workflow Manager actor.

b. Otherwise if no acceptable response has been received

[RTW-11710] The Transfer Requester **SHALL** transition the Request Transfer Task to the FAILURE state.

[RTW-11711] **SHALL** add Referral/Transfer Response Document to the Output Documents for task.

[RTW-11717] **SHALL** mark the workflow as CLOSED.

4. When the Perform Transfer Task reaches the READY state :
  - a. If patient transport is initiated

[RTW-11860] The Transfer Requester **SHALL** transition the Perform Transfer Task to the IN\_PROGRESS state.

[RTW-11861] **SHALL** add Appointment Document to the Input Documents for task.

[RTW-11862] **SHALL** add Transfer Request Document to the Input Documents for task.

[RTW-11863] **SHALL** add Referral/Transfer Response Document to the Output Documents for task.

b. Otherwise if patient transport is not initiated

[RTW-11910] The Transfer Requester **SHALL** transition the Perform Transfer Task to the FAILURE state.

[RTW-11911] **SHALL** add Referral/Transfer Response Document to the Output Documents for task.

[RTW-11917] **SHALL** mark the workflow as CLOSED.

## 5.3 REFERRAL REQUESTER

### 5.3.1 General Requirements

- [RTW-20001] None

### 5.3.2 In the Referral Workflow:

1. When the patient needs a referral :

[RTW-20010] The Referral Requester **SHALL** create a new Request Referral Task in the COMPLETED state.

- [RTW-20011] **SHALL** add **Relevant Clinical documents** to the **Input Documents** for task.
- [RTW-20012] **SHALL** add **Referral Request Document** to the **Output Documents** for task.
- [RTW-20015] **SHALL** set the **<actualOwner>** element of the **<taskDetails>** element to the notification identifier for the Referral Requester actor.
- [RTW-20016] **SHALL** set the **<notificationRecipients>** element of the **<taskDetails>** element to the notification identifier for the Workflow Manager actor.

2. When the Request Information Task reaches the READY state :

- [RTW-20810] The Referral Requester **SHALL** transition the Request Information Task to the COMPLETED state.
  - [RTW-20811] **SHALL** add **Information Request Document** to the **Input Documents** for task.
  - [RTW-20812] **SHALL** add **Information Response Document AND/OR Relevant Clinical Documents** to the **Output Documents** for task.

### 5.3.3 In the Direct Referral Workflow:

1. When the patient needs a referral :

- [RTW-21010] The Referral Requester **SHALL** create a new Request Referral Task in the COMPLETED state.
  - [RTW-21011] **SHALL** add **Relevant Clinical documents** to the **Input Documents** for task.
  - [RTW-21012] **SHALL** add **Referral Request Document** to the **Output Documents** for task.
  - [RTW-21015] **SHALL** set the **<actualOwner>** element of the **<taskDetails>** element to the notification identifier for the Referral Requester actor.
  - [RTW-21016] **SHALL** set the **<notificationRecipients>** element of the **<taskDetails>** element to the notification identifier for the Workflow Manager actor.
- [RTW-21020] The Referral Requester **SHALL** create a new Respond to a Referral Request Task in the READY state.
  - [RTW-21021] **SHALL** add **Referral Request Document** to the **Input Documents** for task.
  - [RTW-21022] **SHALL** add **Relevant Clinical documents** to the **Input Documents** for task.
  - [RTW-21024] **SHALL** set the **<taskInitiator>** element of the **<taskDetails>** element to the notification identifier for the Referral Requester actor.
  - [RTW-21025] **SHALL** set the **<actualOwner>** element of the **<taskDetails>** element to the notification identifier for the Referral/Transfer Receiver actor.
  - [RTW-21026] **SHALL** set the **<notificationRecipients>** element of the **<taskDetails>** element to the notification identifier for the Workflow Manager actor.

2. When the Request Information Task reaches the READY state :

- [RTW-21410] The Referral Requester **SHALL** transition the Request Information Task to the COMPLETED state.
  - [RTW-21411] **SHALL** add **Information Response Document AND/OR Relevant Clinical Documents** to the **Output Documents** for task.

3. When the Respond to a Referral Request Task reaches the COMPLETED state or timeout on response :
  - a. If an acceptable response has been received

[RTW-21660] The Referral Requester **SHALL** create a new Perform Referral Task in the CREATED state.

[RTW-21661] **SHALL** add **Referral Request Document** to the **Input Documents** for task.

[RTW-21662] **SHALL** add **Referral/Transfer Response Document** to the **Input Documents** for task.

[RTW-21664] **SHALL** set the <taskInitiator> element of the <taskDetails> element to the notification identifier for the Referral Requester actor.

[RTW-21665] **SHALL** set the <actualOwner> element of the <taskDetails> element to the notification identifier for the Referral/Transfer Receiver actor.

[RTW-21666] **SHALL** set the <notificationRecipients> element of the <taskDetails> element to the notification identifier for the Workflow Manager actor.

- b. Otherwise if no acceptable response has been received

[RTW-21710] The Referral Requester **SHALL** transition the Request Referral Task to the FAILURE state.

[RTW-21717] **SHALL** mark the workflow as CLOSED.

#### **5.3.4 In the Flexible Referral Workflow:**

1. When the patient needs a referral :

[RTW-22010] The Referral Requester **SHALL** create a new Request Referral Task in the COMPLETED state.

[RTW-22011] **SHALL** add **Relevant Clinical documents** to the **Input Documents** for task.

[RTW-22012] **SHALL** add **Referral Request Document** to the **Output Documents** for task.

[RTW-22015] **SHALL** set the <actualOwner> element of the <taskDetails> element to the notification identifier for the Referral Requester actor.

[RTW-22016] **SHALL** set the <notificationRecipients> element of the <taskDetails> element to the notification identifier for the Workflow Manager actor.

### **5.4 WORKFLOW MANAGER**

#### **5.4.1 General Requirements**

- [RTW-30001] None

#### **5.4.2 In the Transfer Workflow:**

1. When the Dispatch Transfer Task reaches the READY state :
  - a. If no bidding is needed

[RTW-30260] The Workflow Manager **SHALL** create a new Respond to a Transfer Request Task in the READY state.

[RTW-30261] **SHALL** add **Transfer Request Document** to the **Input Documents** for task.

[RTW-30262] **SHALL** add **Relevant Clinical documents** to the **Input Documents** for task.

[RTW-30264] **SHALL** set the <taskInitiator> element of the <taskDetails> element to the notification identifier for the Workflow Manager actor.

[RTW-30265] **SHALL** set the <actualOwner> element of the <taskDetails> element to the notification identifier for the Referral/Transfer Receiver actor.

[RTW-30266] **SHALL** set the <notificationRecipients> element of the <taskDetails> element to the notification identifier for the Workflow Manager actor.

b. Otherwise if bidding is needed

[RTW-30310] The Workflow Manager **SHALL** transition the Dispatch Transfer Task to the COMPLETED state.

[RTW-30311] **SHALL** add **Transfer Request Document** to the **Output Documents** for task.

[RTW-30320] The Workflow Manager **SHALL** create a new Bid on a Transfer Request Task in the READY state.

[RTW-30321] **SHALL** add **Transfer Request Document** to the **Input Documents** for task.

[RTW-30322] **SHALL** add **Relevant Clinical documents** to the **Input Documents** for task.

[RTW-30324] **SHALL** set the <taskInitiator> element of the <taskDetails> element to the notification identifier for the Workflow Manager actor.

[RTW-30325] **SHALL** set the <actualOwner> element of the <taskDetails> element to the notification identifier for the Referral/Transfer Receiver actor.

[RTW-30326] **SHALL** set the <notificationRecipients> element of the <taskDetails> element to the notification identifier for the Workflow Manager actor.

c. Otherwise if transferring to another circle

[RTW-30361] **SHALL** add **Transfer Request Document** to the **Output Documents** for task.

[RTW-30365] **SHALL** set the <actualOwner> element of the <taskDetails> element to the notification identifier for the new Workflow Manager actor.

[RTW-30366] **SHALL** set the <notificationRecipients> element of the <taskDetails> element to the notification identifier for the new Workflow Manager actor.

d. Otherwise if cannot dispatch because no receivers are available

[RTW-30410] The Workflow Manager **SHALL** transition the Dispatch Transfer Task to the FAILURE state.

[RTW-30411] **SHALL** add **Transfer Request Document** to the **Output Documents** for task.

[RTW-30417] **SHALL** mark the workflow as CLOSED.

[RTW-30420] The Workflow Manager **SHALL** transition the Request Transfer Task to the FAILURE state.



- [RTW-30421] **SHALL** add **Relevant Clinical documents** to the **Input Documents** for task.
- [RTW-30422] **SHALL** add **Transfer Request Document** to the **Output Documents** for task.
- [RTW-30427] **SHALL** mark the workflow as **CLOSED**.

2. When the Respond to a Transfer Request Task reaches the **FAILURE** state or the Respond to a Transfer Request Task reaches the **COMPLETED** state or the Bid on a Transfer Request Task reaches the **FAILURE** state :
  - a. If an acceptable response has been received

[RTW-31060] The Workflow Manager **SHALL** create a new Perform Transfer Task in the **READY** state.

[RTW-31061] **SHALL** add **Referral/Transfer Response Document** to the **Output Documents** for task.

[RTW-31065] **SHALL** set the **<actualOwner>** element of the **<taskDetails>** element to the notification identifier for the Workflow Manager actor.

[RTW-31066] **SHALL** set the **<notificationRecipients>** element of the **<taskDetails>** element the notification identifier for the Workflow Manager actor.

- b. Otherwise if no acceptable response has been received, but some responses still are pending.

No additional constraints.

- c. Otherwise if no acceptable response has been received and no responses pending and escalation possible

[RTW-31160] The Workflow Manager **SHALL** create a new Perform Transfer Task in the **READY** state.

[RTW-31161] **SHALL** add **Referral/Transfer Response Document** to the **Output Documents** for task.

[RTW-31165] **SHALL** set the **<actualOwner>** element of the **<taskDetails>** element to the notification identifier for the Workflow Manager actor.

[RTW-31166] **SHALL** set the **<notificationRecipients>** element of the **<taskDetails>** element the notification identifier for the Workflow Manager actor.

[RTW-31170] The Workflow Manager **SHALL** transition the Request Transfer Task to the **FAILURE** state.

[RTW-31171] **SHALL** add **Relevant Clinical documents** to the **Input Documents** for task.

[RTW-31172] **SHALL** add **Transfer Request Document** to the **Output Documents** for task.

[RTW-31177] **SHALL** mark the workflow as **CLOSED**.

- d. Otherwise if no acceptable response has been received and no responses are pending and no escalation is possible

[RTW-31210] The Workflow Manager **SHALL** create a new Perform Transfer Task in the **FAILURE** state.

[RTW-31211] **SHALL** add **Referral/Transfer Response Document** to the **Output Documents** for task.

[RTW-31215] **SHALL** set the **<actualOwner>** element of the **<taskDetails>** element to the notification identifier for the Workflow Manager actor.

[RTW-31216] **SHALL** set the **<notificationRecipients>** element of the **<taskDetails>** element the notification identifier for the Workflow Manager actor.

[RTW-31217] **SHALL** mark the workflow as CLOSED.

3. When respond to transfer request or bid on a transfer request timeout :
  - a. If can resolve through escalation

[RTW-31260] The Workflow Manager **SHALL** create a new Perform Transfer Task in the READY state.

[RTW-31261] **SHALL** add **Referral/Transfer Response Document** to the **Output Documents** for task.

[RTW-31265] **SHALL** set the **<actualOwner>** element of the **<taskDetails>** element to the notification identifier for the Workflow Manager actor.

[RTW-31266] **SHALL** set the **<notificationRecipients>** element of the **<taskDetails>** element the notification identifier for the Workflow Manager actor.

- b. Otherwise if cannot resolve through escalation

[RTW-31310] The Workflow Manager **SHALL** create a new Perform Transfer Task in the FAILURE state.

[RTW-31311] **SHALL** add **Referral/Transfer Response Document** to the **Output Documents** for task.

[RTW-31315] **SHALL** set the **<actualOwner>** element of the **<taskDetails>** element to the notification identifier for the Workflow Manager actor.

[RTW-31316] **SHALL** set the **<notificationRecipients>** element of the **<taskDetails>** element the notification identifier for the Workflow Manager actor.

[RTW-31317] **SHALL** mark the workflow as CLOSED.

[RTW-31320] The Workflow Manager **SHALL** transition the Request Transfer Task to the FAILURE state.

[RTW-31321] **SHALL** add **Relevant Clinical documents** to the **Input Documents** for task.

[RTW-31322] **SHALL** add **Transfer Request Document** to the **Output Documents** for task.

[RTW-31327] **SHALL** mark the workflow as CLOSED.

### **5.4.3 In the Referral Workflow:**

1. When the Request Referral Task reaches the COMPLETED state :
  - a. If receivers are available and no bidding is needed

[RTW-31260] The Workflow Manager **SHALL** create a new Dispatch Referral Task in the COMPLETED state.

[RTW-31261] **SHALL** add **Transfer Request Document** to the **Output Documents** for task.

[RTW-31265] **SHALL** set the **<actualOwner>** element of the **<taskDetails>** element to the notification identifier for the Workflow Manager actor.

[RTW-31266] **SHALL** set the **<notificationRecipients>** element of the **<taskDetails>** element to the notification identifier for the Workflow Manager actor.

[RTW-31270] The Workflow Manager **SHALL** create a new Respond to a Referral Request Task in the READY state.

[RTW-31271] **SHALL** add **Referral Request Document** to the **Input Documents** for task.

[RTW-31272] **SHALL** add **Relevant Clinical documents** to the **Input Documents** for task.

[RTW-31273] **SHALL** add **Referral Request Document** to the **Output Documents** for task.

[RTW-31274] **SHALL** set the **<taskInitiator>** element of the **<taskDetails>** element to the notification identifier for the Workflow Manager actor.

[RTW-31275] **SHALL** set the **<actualOwner>** element of the **<taskDetails>** element to the notification identifier for the Referral/Transfer Receiver actor.

[RTW-31276] **SHALL** set the **<notificationRecipients>** element of the **<taskDetails>** element to the notification identifier for the Workflow Manager actor.

b. Otherwise if receivers are available and bidding is needed

[RTW-31310] The Workflow Manager **SHALL** create a new Dispatch Referral Task in the COMPLETED state.

[RTW-31311] **SHALL** add **Referral Request Document** to the **Output Documents** for task.

[RTW-31315] **SHALL** set the **<actualOwner>** element of the **<taskDetails>** element to the notification identifier for the Workflow Manager actor.

[RTW-31316] **SHALL** set the **<notificationRecipients>** element of the **<taskDetails>** element to the notification identifier for the Workflow Manager actor.

[RTW-31320] The Workflow Manager **SHALL** create a new Bid on a Referral Request Task in the READY state.

[RTW-31321] **SHALL** add **Referral Request Document** to the **Input Documents** for task.

[RTW-31322] **SHALL** add **Relevant Clinical documents** to the **Input Documents** for task.

[RTW-31323] **SHALL** add **Referral Request Document** to the **Output Documents** for task.

[RTW-31324] **SHALL** set the **<taskInitiator>** element of the **<taskDetails>** element to the notification identifier for the Workflow Manager actor.

[RTW-31325] **SHALL** set the **<actualOwner>** element of the **<taskDetails>** element to the notification identifier for the Referral/Transfer Receiver actor.

[RTW-31326] **SHALL** set the **<notificationRecipients>** element of the **<taskDetails>** element to the notification identifier for the Workflow Manager actor.

c. Otherwise if transferring to another circle

[RTW-31365] **SHALL** set the **<actualOwner>** element of the **<taskDetails>** element to the notification identifier for the new Workflow Manager actor.

[RTW-31366] **SHALL** set the **<notificationRecipients>** element of the **<taskDetails>** element to the notification identifier for the new Workflow Manager actor.

- d. Otherwise if cannot dispatch because no receivers are available

[RTW-31410] The Workflow Manager **SHALL** create a new Dispatch Referral Task in the FAILURE state.

[RTW-31411] **SHALL** add **Referral Request Document** to the **Output Documents** for task.

[RTW-31415] **SHALL** set the <actualOwner> element of the <taskDetails> element to the notification identifier for the Workflow Manager actor.

[RTW-31416] **SHALL** set the <notificationRecipients> element of the <taskDetails> element the notification identifier for the Workflow Manager actor.

[RTW-31417] **SHALL** mark the workflow as CLOSED.

[RTW-31420] The Workflow Manager **SHALL** transition the Request Referral Task to the FAILURE state.

[RTW-31421] **SHALL** add **Relevant Clinical documents** to the **Input Documents** for task.

[RTW-31422] **SHALL** add **Referral Request Document** to the **Output Documents** for task.

[RTW-31427] **SHALL** mark the workflow as CLOSED.

- 2. When the Respond to a Referral Request Task reaches the COMPLETED state or the Respond to a Referral Request Task reaches the FAILURE state or the Respond to a Referral Request Task reaches the FAILURE state :
  - a. If an acceptable response has been received

[RTW-32060] The Workflow Manager **SHALL** create a new Perform Referral Task in the CREATED state.

[RTW-32061] **SHALL** add **Referral/Transfer Response Document** to the **Output Documents** for task.

[RTW-32064] **SHALL** set the <taskInitiator> element of the <taskDetails> element to the notification identifier for the Workflow Manager actor.

[RTW-32065] **SHALL** set the <actualOwner> element of the <taskDetails> element to the notification identifier for the Referral/Transfer Receiver actor.

[RTW-32066] **SHALL** set the <notificationRecipients> element of the <taskDetails> element the notification identifier for the Workflow Manager actor.

- b. Otherwise if responses are still pending

No additional constraints.

- c. Otherwise if no acceptable response is pending and can resolve through escalation

[RTW-32160] The Workflow Manager **SHALL** create a new Perform Referral Task in the CREATED state.

[RTW-32161] **SHALL** add **Referral/Transfer Response Document** to the **Output Documents** for task.

[RTW-32164] **SHALL** set the <taskInitiator> element of the <taskDetails> element to the notification identifier for the Workflow Manager actor.

[RTW-32165] **SHALL** set the <actualOwner> element of the <taskDetails> element to the notification identifier for the Referral/Transfer Receiver actor.

[RTW-32166] **SHALL** set the <notificationRecipients> element of the <taskDetails> element to the notification identifier for the Workflow Manager actor.

d. Otherwise if no acceptable response is pending and cannot resolve through escalation

[RTW-32210] The Workflow Manager **SHALL** create a new Perform Referral Task in the FAILURE state.

[RTW-32211] **SHALL** add Referral/Transfer Response Document to the Output Documents for task.

[RTW-32214] **SHALL** set the <taskInitiator> element of the <taskDetails> element to the notification identifier for the Workflow Manager actor.

[RTW-32215] **SHALL** set the <actualOwner> element of the <taskDetails> element to the notification identifier for the Referral/Transfer Receiver actor.

[RTW-32216] **SHALL** set the <notificationRecipients> element of the <taskDetails> element to the notification identifier for the Workflow Manager actor.

[RTW-32217] **SHALL** mark the workflow as CLOSED.

[RTW-32220] The Workflow Manager **SHALL** transition the Request Referral Task to the FAILURE state.

[RTW-32221] **SHALL** add Relevant Clinical documents to the Input Documents for task.

[RTW-32222] **SHALL** add Referral Request Document to the Output Documents for task.

[RTW-32227] **SHALL** mark the workflow as CLOSED.

3. When respond to referral request or bid on a referral request timeout :  
a. If can resolve through escalation

[RTW-32260] The Workflow Manager **SHALL** create a new Perform Referral Task in the CREATED state.

[RTW-32261] **SHALL** add Referral/Transfer Response Document to the Output Documents for task.

[RTW-32264] **SHALL** set the <taskInitiator> element of the <taskDetails> element to the notification identifier for the Workflow Manager actor.

[RTW-32265] **SHALL** set the <actualOwner> element of the <taskDetails> element to the notification identifier for the Referral/Transfer Receiver actor.

[RTW-32266] **SHALL** set the <notificationRecipients> element of the <taskDetails> element to the notification identifier for the Workflow Manager actor.

b. Otherwise if cannot resolve through escalation

[RTW-32310] The Workflow Manager **SHALL** create a new Perform Referral Task in the FAILURE state.

[RTW-32311] **SHALL** add **Referral/Transfer Response Document** to the **Output Documents** for task.

[RTW-32314] **SHALL** set the **<taskInitiator>** element of the **<taskDetails>** element to the notification identifier for the Workflow Manager actor.

[RTW-32315] **SHALL** set the **<actualOwner>** element of the **<taskDetails>** element to the notification identifier for the Referral/Transfer Receiver actor.

[RTW-32316] **SHALL** set the **<notificationRecipients>** element of the **<taskDetails>** element to the notification identifier for the Workflow Manager actor.

[RTW-32317] **SHALL** mark the workflow as CLOSED.

[RTW-32320] The Workflow Manager **SHALL** transition the Request Referral Task to the FAILURE state.

[RTW-32321] **SHALL** add **Relevant Clinical documents** to the **Input Documents** for task.

[RTW-32322] **SHALL** add **Referral Request Document** to the **Output Documents** for task.

[RTW-32327] **SHALL** mark the workflow as CLOSED.

## 5.5 REFERRAL/TRANSFER RECEIVER

### 5.5.1 General Requirements

- [RTW-40001] None

### 5.5.2 In the Transfer Workflow:

1. When the Bid on a Transfer Request Task reaches the READY state :
  - a. If bidding not acceptable

[RTW-40460] The Referral/Transfer Receiver **SHALL** transition the Bid on a Transfer Request Task to the FAILURE state.

- b. Otherwise if bidding acceptable

[RTW-40510] The Referral/Transfer Receiver **SHALL** transition the Bid on a Transfer Request Task to the COMPLETED state.

[RTW-40520] The Referral/Transfer Receiver **SHALL** create a new Respond to a Transfer Request Task in the READY state.

[RTW-40521] **SHALL** add **Transfer Request Document** to the **Input Documents** for task.

[RTW-40522] **SHALL** add **Relevant Clinical documents** to the **Input Documents** for task.

[RTW-40525] **SHALL** set the **<actualOwner>** element of the **<taskDetails>** element to the notification identifier for the Referral/Transfer Receiver actor.

[RTW-40526] **SHALL** set the **<notificationRecipients>** element of the **<taskDetails>** element to the notification identifier for the Workflow Manager actor.

2. When the Respond to a Transfer Request Task reaches the READY state or the Request Information Task reaches the COMPLETED state :
  - a. If more information is needed

[RTW-40660] The Referral/Transfer Receiver **SHALL** create a new Request Information Task in the READY state.

[RTW-40661] **SHALL** add **Information Request Document** to the **Input Documents** for task.

[RTW-40664] **SHALL** set the <taskInitiator> element of the <taskDetails> element to the notification identifier for the Referral/Transfer Receiver actor.

[RTW-40665] **SHALL** set the <actualOwner> element of the <taskDetails> element to the notification identifier for the Transfer Requester actor.

[RTW-40666] **SHALL** set the <notificationRecipients> element of the <taskDetails> element to the notification identifier for the Workflow Manager actor.

b. Otherwise if no need for more information and can handle the transfer

[RTW-40710] The Referral/Transfer Receiver **SHALL** transition the Respond to a Transfer Request Task to the COMPLETED state.

[RTW-40711] **SHALL** add **Transfer Request Document** to the **Input Documents** for task.

[RTW-40712] **SHALL** add **Relevant Clinical documents** to the **Input Documents** for task.

[RTW-40713] **SHALL** add **Referral/Transfer Response Document** to the **Output Documents** for task.

c. Otherwise if no need for more information and cannot handle the transfer

[RTW-40760] The Referral/Transfer Receiver **SHALL** transition the Respond to a Transfer Request Task to the FAILURE state.

[RTW-40761] **SHALL** add **Transfer Request Document** to the **Input Documents** for task.

[RTW-40762] **SHALL** add **Relevant Clinical documents** to the **Input Documents** for task.

[RTW-40763] **SHALL** add **Referral/Transfer Response Document** to the **Output Documents** for task.

3. When the Perform Transfer Task reaches the IN\_PROGRESS state :

a. If the patient's admission is completed within reasonable time frame

[RTW-41660] The Referral/Transfer Receiver **SHALL** transition the Perform Transfer Task to the COMPLETED state.

[RTW-41661] **SHALL** add **Referral/Transfer Response Document** to the **Input Documents** for task.

[RTW-41667] **SHALL** mark the workflow as CLOSED.

b. Otherwise if the patient's admission is completed at a different hospital

[RTW-41710] The Referral/Transfer Receiver **SHALL** transition the Perform Transfer Task to the COMPLETED state.

[RTW-41711] **SHALL** add **Referral/Transfer Response Document** to the **Input Documents** for task.

[RTW-41717] **SHALL** mark the workflow as CLOSED.

- c. Otherwise if the patient's admission is not completed at a different hospital and was not completed within reasonable time frame

[RTW-41760] The Referral/Transfer Receiver **SHALL** transition the Perform Transfer Task to the FAILURE state.

- [RTW-41761] **SHALL** add **Referral/Transfer Response Document** to the **Input Documents** for task.  
[RTW-41767] **SHALL** mark the workflow as CLOSED.

### 5.5.3 In the Referral Workflow:

1. When the Bid on a Referral Request Task reaches the READY state :
  - a. If bidding not acceptable

[RTW-41460] The Referral/Transfer Receiver **SHALL** transition the Bid on a Referral Request Task to the FAILURE state.

- b. Otherwise if bidding acceptable

[RTW-41510] The Referral/Transfer Receiver **SHALL** create a new Respond to a Transfer Request Task in the READY state.

[RTW-41511] **SHALL** add **Transfer Request Document** to the **Input Documents** for task.

[RTW-41512] **SHALL** add **Relevant Clinical documents** to the **Input Documents** for task.

[RTW-41515] **SHALL** set the <actualOwner> element of the <taskDetails> element to the notification identifier for the Referral/Transfer Receiver actor.

[RTW-41516] **SHALL** set the <notificationRecipients> element of the <taskDetails> element the notification identifier for the Workflow Manager actor.

[RTW-41520] The Referral/Transfer Receiver **SHALL** transition the Bid on a Referral Request Task to the COMPLETED state.

[RTW-41527] **SHALL** mark the workflow as CLOSED.

2. When the Respond to a Referral Request Task reaches the READY state or the Request Information Task reaches the COMPLETED state :
    - a. If more information is needed

[RTW-41660] The Referral/Transfer Receiver **SHALL** create a new Request Information Task in the READY state.

[RTW-41661] **SHALL** add **Information Request Document** to the **Input Documents** for task.

[RTW-41664] **SHALL** set the <taskInitiator> element of the <taskDetails> element to the notification identifier for the Referral/Transfer Receiver actor.

[RTW-41665] **SHALL** set the <actualOwner> element of the <taskDetails> element to the notification identifier for the Referral Requester actor.

[RTW-41666] **SHALL** set the <notificationRecipients> element of the <taskDetails> element the notification identifier for the Workflow Manager actor.



b. Otherwise if no need for more information and can handle the referral

[RTW-41710] The Referral/Transfer Receiver **SHALL** transition the Respond to a Referral Request Task to the COMPLETED state.

[RTW-41711] **SHALL** add **Referral Request Document** to the **Input Documents** for task.

[RTW-41712] **SHALL** add **Relevant Clinical documents** to the **Input Documents** for task.

[RTW-41713] **SHALL** add **Referral/Transfer Response Document** to the **Output Documents** for task.

c. Otherwise if no need for more information and cannot handle the referral

[RTW-41760] The Referral/Transfer Receiver **SHALL** transition the Respond to a Referral Request Task to the FAILURE state.

[RTW-41761] **SHALL** add **Referral Request Document** to the **Input Documents** for task.

[RTW-41762] **SHALL** add **Relevant Clinical documents** to the **Input Documents** for task.

[RTW-41763] **SHALL** add **Referral/Transfer Response Document** to the **Output Documents** for task.

d. Otherwise if timeout occurs waiting for more information

[RTW-41810] The Referral/Transfer Receiver **SHALL** transition the Request Referral Task to the FAILURE state.

[RTW-41811] **SHALL** add **Referral/Transfer Response Document** to the **Output Documents** for task.

[RTW-41817] **SHALL** mark the workflow as CLOSED.

e. Otherwise if transfer is cancelled

[RTW-41860] The Referral/Transfer Receiver **SHALL** transition the Request Referral Task to the FAILURE state.

[RTW-41861] **SHALL** add **Referral/Transfer Response Document** to the **Output Documents** for task.

[RTW-41867] **SHALL** mark the workflow as CLOSED.

3. When the Perform Referral Task reaches the CREATED state :

[RTW-42410] The Referral/Transfer Receiver **SHALL** transition the Perform Referral Task to the READY state.

[RTW-42411] **SHALL** add **Appointment Document** to the **Input Documents** for task.

[RTW-42412] **SHALL** add **Referral/Transfer Response Document** to the **Input Documents** for task.

[RTW-42413] **SHALL** add **Referral Request Document** to the **Output Documents** for task.

4. When the Perform Referral Task reaches the READY state :
  - a. If the referral occurs within a reasonable time frame

[RTW-42660] The Referral/Transfer Receiver **SHALL** transition the Perform Referral Task to the IN\_PROGRESS state.

[RTW-42661] **SHALL** add **Referral/Transfer Response Document** to the **Input Documents** for task.

[RTW-42662] **SHALL** add **Referral Request Document** to the **Output Documents** for task.

- b. Otherwise if the patient arrives at another organization for the referral rather than the one selected

[RTW-42710] The Referral/Transfer Receiver **SHALL** transition the Perform Referral Task to the IN\_PROGRESS state.

[RTW-42711] **SHALL** add **Referral/Transfer Response Document** to the **Input Documents** for task.

[RTW-42712] **SHALL** add **Referral Request Document** to the **Output Documents** for task.

- c. Otherwise if the referral does not occur within a reasonable time frame and another organization has not already started the referral

[RTW-42760] The Referral/Transfer Receiver **SHALL** transition the Perform Referral Task to the FAILURE state.

[RTW-42761] **SHALL** add **Referral/Transfer Response Document** to the **Input Documents** for task.

[RTW-42762] **SHALL** add **Referral Request Document** to the **Output Documents** for task.

[RTW-42767] **SHALL** mark the workflow as CLOSED.

5. When the Perform Referral Task reaches the IN\_PROGRESS state :
  - a. If the referral completes successfully

[RTW-42860] The Referral/Transfer Receiver **SHALL** transition the Perform Referral Task to the COMPLETED state.

[RTW-42861] **SHALL** add **Referral/Transfer Response Document** to the **Input Documents** for task.

[RTW-42862] **SHALL** add **Referral Result Document** to the **Output Documents** for task.

[RTW-42867] **SHALL** mark the workflow as CLOSED.

- b. Otherwise if the referral did not complete successfully

[RTW-42910] The Referral/Transfer Receiver **SHALL** transition the Perform Referral Task to the FAILURE state.

[RTW-42911] **SHALL** add **Referral/Transfer Response Document** to the **Input Documents** for task.

[RTW-42912] **SHALL** add **Referral Result Document** to the **Output Documents** for task.

[RTW-42917] **SHALL** mark the workflow as CLOSED.

#### 5.5.4 In the Direct Transfer Workflow:

1. When the Respond to a Transfer Request Task reaches the READY state or the Request Information Task reaches the COMPLETED state :
  - a. If more information is needed

[RTW-42260] The Referral/Transfer Receiver **SHALL** create a new Request Information Task in the READY state.

[RTW-42261] **SHALL** add **Information Request Document** to the **Input Documents** for task.

[RTW-42264] **SHALL** set the <taskInitiator> element of the <taskDetails> element to the notification identifier for the Referral/Transfer Receiver actor.

[RTW-42265] **SHALL** set the <actualOwner> element of the <taskDetails> element to the notification identifier for the Transfer Requester actor.

[RTW-42266] **SHALL** set the <notificationRecipients> element of the <taskDetails> element to the notification identifier for the Workflow Manager actor.

- b. Otherwise if no need for more information and can handle the transfer

[RTW-42310] The Referral/Transfer Receiver **SHALL** transition the Respond to a Transfer Request Task to the COMPLETED state.

[RTW-42311] **SHALL** add **Referral/Transfer Response Document** to the **Output Documents** for task.

- c. Otherwise if no need for more information and cannot handle the transfer

[RTW-42360] The Referral/Transfer Receiver **SHALL** transition the Respond to a Transfer Request Task to the FAILURE state.

[RTW-42361] **SHALL** add **Referral/Transfer Response Document** to the **Output Documents** for task.

- d. Otherwise if timeout occurs waiting for more information

[RTW-42410] The Referral/Transfer Receiver **SHALL** transition the Request Transfer Task to the FAILURE state.

[RTW-42411] **SHALL** add **Referral/Transfer Response Document** to the **Output Documents** for task.

[RTW-42417] **SHALL** mark the workflow as CLOSED.

- e. Otherwise if timeout occurs waiting for more information

[RTW-42460] The Referral/Transfer Receiver **SHALL** transition the Request Transfer Task to the FAILURE state.

[RTW-42461] **SHALL** add **Referral/Transfer Response Document** to the **Output Documents** for task.

[RTW-42467] **SHALL** mark the workflow as CLOSED.

[RTW-42370] The Referral/Transfer Receiver **SHALL** transition the Request Transfer Task to the FAILURE state.

[RTW-42371] **SHALL** add **Referral/Transfer Response Document** to the **Output Documents** for task.

[RTW-42377] **SHALL** mark the workflow as CLOSED.

f. Otherwise if timeout occurs waiting for more information

[RTW-42410] The Referral/Transfer Receiver **SHALL** transition the Request Transfer Task to the FAILURE state.

[RTW-42411] **SHALL** add **Referral/Transfer Response Document** to the **Output Documents** for task.

[RTW-42417] **SHALL** mark the workflow as CLOSED.

g. Otherwise if transfer is cancelled

[RTW-42460] The Referral/Transfer Receiver **SHALL** transition the Request Transfer Task to the FAILURE state.

[RTW-42461] **SHALL** add **Referral/Transfer Response Document** to the **Output Documents** for ask.

[RTW-42467] **SHALL** mark the workflow as CLOSED.

2. When the Perform Transfer Task reaches the IN\_PROGRESS state :
  - a. If the patient transport is completed within reasonable time frame

[RTW-43060] The Referral/Transfer Receiver **SHALL** transition the Perform Transfer Task to the COMPLETED state.

[RTW-43061] **SHALL** add **Referral/Transfer Response Document** to the **Input Documents** for task.

[RTW-43067] **SHALL** mark the workflow as CLOSED.

b. Otherwise if the patient's admission is completed at a different hospital

[RTW-43110] The Referral/Transfer Receiver **SHALL** transition the Perform Transfer Task to the COMPLETED state.

[RTW-43111] **SHALL** add **Referral/Transfer Response Document** to the **Input Documents** for task.

[RTW-43117] **SHALL** mark the workflow as CLOSED.

c. Otherwise if the patient's admission is not completed at a different hospital and is not completed within reasonable time frame.

[RTW-43160] The Referral/Transfer Receiver **SHALL** transition the Perform Transfer Task to the FAILURE state.

[RTW-43161] **SHALL** add **Referral/Transfer Response Document** to the **Input Documents** for task.  
[RTW-43167] **SHALL** mark the workflow as CLOSED.

### 5.5.5 In the Direct Referral Workflow:

1. When the Respond to a Referral Request Task reaches the READY state or the Request Information Task reaches the COMPLETED state :
  - a. If more information is needed

[RTW-43260] The Referral/Transfer Receiver **SHALL** create a new Request Information Task in the READY state.

[RTW-43261] **SHALL** add **Information Request Document** to the **Input Documents** for task.

[RTW-43264] **SHALL** set the <taskInitiator> element of the <taskDetails> element to the notification identifier for the Referral/Transfer Receiver actor.

[RTW-43265] **SHALL** set the <actualOwner> element of the <taskDetails> element to the notification identifier for the Referral Requester actor.

[RTW-43266] **SHALL** set the <notificationRecipients> element of the <taskDetails> element to the notification identifier for the Workflow Manager actor.

- b. Otherwise if no need for more information and can handle the referral.

[RTW-43310] The Referral/Transfer Receiver **SHALL** transition the Respond to a Referral Request Task to the COMPLETED state.

[RTW-43311] **SHALL** add **Referral/Transfer Response Document** to the **Output Documents** for task.

- c. Otherwise if no need for more information and cannot handle the referral.

[RTW-43360] The Referral/Transfer Receiver **SHALL** transition the Respond to a Referral Request Task to the FAILURE state.

[RTW-43361] **SHALL** add **Referral/Transfer Response Document** to the **Output Documents** for task.

[RTW-43370] The Referral/Transfer Receiver **SHALL** transition the Request Referral Task to the FAILURE state.

[RTW-43371] **SHALL** add **Referral Request Document** to the **Output Documents** for task.

[RTW-43377] **SHALL** mark the workflow as CLOSED.

- d. Otherwise if timeout occurs waiting for more information.

[RTW-43410] The Referral/Transfer Receiver **SHALL** transition the Request Referral Task to the FAILURE state.

[RTW-43411] **SHALL** add **Referral/Transfer Response Document** to the **Output Documents** for task.

[RTW-43417] **SHALL** mark the workflow as **CLOSED**.

e. Otherwise if transfer is cancelled

[RTW-43460] The Referral/Transfer Receiver **SHALL** transition the Request Referral Task to the **FAILURE** state.

[RTW-43461] **SHALL** add **Referral/Transfer Response Document** to the **Output Documents** for ask.

[RTW-43467] **SHALL** mark the workflow as **CLOSED**.

2. When the Perform Referral Task reaches the **CREATED** state :

[RTW-43810] The Referral/Transfer Receiver **SHALL** transition the Perform Referral Task to the **READY** state.

[RTW-43811] **SHALL** add **Appointment Document** to the **Input Documents** for task.

3. When the Perform Referral Task reaches the **READY** state :

a. If the patient arrives for the referral within a reasonable time frame

[RTW-44060] The Referral/Transfer Receiver **SHALL** transition the Perform Referral Task to the **IN\_PROGRESS** state.

[RTW-44061] **SHALL** add **Referral/Transfer Response Document** to the **Input Documents** for task.

b. Otherwise if the patient does not arrive for the referral within a reasonable time frame

[RTW-44110] The Referral/Transfer Receiver **SHALL** transition the Perform Referral Task to the **FAILURE** state.

[RTW-44111] **SHALL** add **Referral/Transfer Response Document** to the **Input Documents** for task.

[RTW-44117] **SHALL** mark the workflow as **CLOSED**.

4. When the Perform Referral Task reaches the **IN\_PROGRESS** state :

a. If referral completes successfully

[RTW-44260] The Referral/Transfer Receiver **SHALL** transition the Perform Referral Task to the **COMPLETED** state.

[RTW-44261] **SHALL** add **Referral Result Document** to the **Output Documents** for task.

[RTW-44267] **SHALL** mark the workflow as **CLOSED**.

b. Otherwise if referral does not complete successfully.

[RTW-44310] The Referral/Transfer Receiver **SHALL** transition the Perform Referral Task to the FAILURE state.

[RTW-44311] **SHALL** add **Referral Result Document** to the **Output Documents** for task.

[RTW-44317] **SHALL** mark the workflow as CLOSED.

### 5.5.6 In the Flexible Referral Workflow:

1. When the Request Referral Task reaches the COMPLETED state :

[RTW-44210] The Referral/Transfer Receiver **SHALL** create a new Perform Referral Task in the CREATED state.

[RTW-44211] **SHALL** add **Appointment Document** to the **Input Documents** for task.

[RTW-44212] **SHALL** add **Referral Request Document** to the **Input Documents** for task.

[RTW-44215] **SHALL** set the <actualOwner> element of the <taskDetails> element to the notification identifier for the Referral/Transfer Receiver actor.

[RTW-44216] **SHALL** set the <notificationRecipients> element of the <taskDetails> element the notification identifier for the Workflow Manager actor.

2. When the Perform Referral Task reaches the CREATED state :
  - a. If the patient arrives for referral within a reasonable time frame

[RTW-44460] The Referral/Transfer Receiver **SHALL** transition the Perform Referral Task to the IN\_PROGRESS state.

[RTW-44461] **SHALL** add **Referral Request Document** to the **Input Documents** for task.

[RTW-44462] **SHALL** add **Referral/Transfer Response Document** to the **Output Documents** for task.

- b. Otherwise if the patient does not arrive for referral within a reasonable time frame

[RTW-44510] The Referral/Transfer Receiver **SHALL** transition the Perform Referral Task to the FAILURE state.

[RTW-44511] **SHALL** add **Referral Request Document** to the **Input Documents** for task.

[RTW-44517] **SHALL** mark the workflow as CLOSED.

3. When the Perform Referral Task reaches the IN\_PROGRESS state :
  - a. If referral is completed successfully

[RTW-44660] The Referral/Transfer Receiver **SHALL** transition the Perform Referral Task to the COMPLETED state.

[RTW-44661] **SHALL** add **Referral Request Document** to the **Input Documents** for task.

[RTW-44662] **SHALL** add **Referral Result Document** to the **Output Documents** for task.

[RTW-44667] **SHALL** mark the workflow as CLOSED.

- b. Otherwise if referral is not completed successfully

[RTW-44710] The Referral/Transfer Receiver **SHALL** transition the Perform Referral Task to the FAILURE state.

[RTW-44711] **SHALL** add **Referral Request Document** to the **Input Documents** for task.

[RTW-44712] **SHALL** add **Referral Result Document** to the **Output Documents** for task.

[RTW-44717] **SHALL** mark the workflow as CLOSED.



## 6. REFERENCED DOCUMENTS AND STANDARDS

The following Saudi eHealth documents are referenced by this interoperability specification.

*TABLE 6-1 INTERNAL REFERENCES*

MOH DOCUMENT	DESCRIPTION
IS0001 Saudi eHealth Core Interoperability Specification for KSA-Wide Patient Demographic Query	Documents the specifications required to obtain patient IDs and demographic information for the patient. It is used to ensure that the nationwide Health ID is used to register laboratory orders for the correct patient.
IS0007 Saudi eHealth Core Interoperability Specification for Clinical Notes and Summaries	Documents the specifications required to provide a synopsis of an encounter and detailed information about a specific type of encounter (e.g., Operative Note) with a patient.
IS0101 Saudi eHealth Security and Privacy Interoperability Specification	Specifies the interoperability standards and profiles along with the Saudi specific constraints that are required to provide the technical security measures, data protection, and privacy management that will facilitate the implementation of the Saudi Health Information Exchange Policies in the Kingdom of Saudi Arabia among communicating IT systems.
IS0102 Saudi eHealth Document Sharing Interoperability Specification	Forms a "container" for set of requirements that complements the IHE XDS Profile with Saudi eHealth specific constraints when it is called upon by any of the Core Interoperability Specifications.
IS0106 Saudi eHealth Clinical Documents Constrains Interoperability Specifications	Specifies common constraints for clinical documents such as data elements of document headers that are common across the Saudi eHealth Project.
IS302 Saudi Health Information Exchange Policies	Contains the policies and supporting definitions that support the security and privacy aspects of the Saudi Health Information Exchange. The Saudi Health Information Exchange Policies apply to all individuals and organizations that have access to the Saudi Health Information Exchange managed health records, including those connected to the Saudi Health Information Exchange, their Business Associates, as well as any subcontractors of Business Associates. These policies apply to all information provided to or retrieved from the Saudi Health Information Exchange.
UC0010 Saudi eHealth eReferral and eTransfer Use Case	Specifies the Saudi eHealth Interoperability Use Cases applicable to existing and new information systems to be connected to the national Saudi Health Exchange (HIE) platform. Each Use Case provides one or more technical scenarios that convey how the system should interact with the end user, or another system, to achieve a specific business goal. The Use Case applicable to this document is Clinical Notes and Summaries. This Use Case describes the ability to create and share clinical notes and summaries for the purpose of transition of care via the HIE. This Use Case also describes the ability to retrieve clinical medical documentation and clinical data from the HIE for the purpose of patient care.

TABLE 6-2 EXTERNAL REFERENCES

STANDARD	DESCRIPTION
Health Level Seven (HL7) Clinical Document Architecture Release 2 (CDA R2)	An XML-based document markup standard that specifies the structure and semantics of clinical documents for the purpose of exchange. CDA R2 further builds upon the Version 3.0 Reference Information Model (RIM) Standard. For more information, see <a href="http://www.hl7.org/implement/standards/product_brief.cfm?product_id=7">http://www.hl7.org/implement/standards/product_brief.cfm?product_id=7</a>
IHE IT Infrastructure (ITI) Technical Framework – Volume 1 (ITI TF-1) Integrations Profiles, Section 10  Cross-Enterprise Document Sharing (XDS.b)	The Cross-Enterprise Document Sharing (XDS.b) IHE Integration Profile facilitates the registration, distribution and access across health enterprises of patient electronic health records. This profile is focused on providing a standards-based specification for managing the sharing of documents between healthcare enterprises, ranging from a private physician office to a clinic to an acute care in-patient facility.  May be obtained at <a href="http://www.ihe.net/Technical_Frameworks/#iti">http://www.ihe.net/Technical_Frameworks/#iti</a>
IHE IT Infrastructure (ITI) Technical Framework – Volume 1 (ITI TF-1) Integrations Profiles, Section 13 Cross-Enterprise User Attestation (XUA) profile	Cross-Enterprise User Assertion Profile (XUA) - provides a means to communicate claims about the identity of an authenticated principal (user, application, system...) in transactions that cross enterprise boundaries. To provide accountability in these cross-enterprise transactions there is a need to identify the requesting principal in a way that enables the receiver to make access decisions and generate the proper audit entries. The XUA Profile supports enterprises that have chosen to have their own user directory with their own unique method of authenticating the users, as well as others that may have chosen to use a third party to perform the authentication.  May be obtained at <a href="http://www.ihe.net/Technical_Frameworks/#iti">http://www.ihe.net/Technical_Frameworks/#iti</a>
IHE IT Infrastructure (ITI) Technical Framework – Volume 1 (ITI TF-1) Integrations Profiles, Section 19 – Basic Patient Privacy Consent (BPPC)	Basic Patient Privacy Consents (BPPC) provides a mechanism to record the patient privacy consent(s) and a method for Content Consumers to use to enforce the privacy consent appropriate to the use. This profile complements XDS by describing a mechanism whereby an XDS Affinity Domain can develop and implement multiple privacy policies, and describes how that mechanism can be integrated with the access control mechanisms supported by the XDS Actors (e.g. EHR systems).  May be obtained at <a href="http://www.ihe.net/Technical_Frameworks/#iti">http://www.ihe.net/Technical_Frameworks/#iti</a>
IHE IT Infrastructure (ITI) Technical Framework – Volume 3 (ITI TF-3) Integrations Profiles, Section 4 Metadata used in Document Sharing profiles	Describes the metadata that is used in IHE profiles designed for sharing documents (Document Sharing profiles). The Document Sharing profiles are implementing the Document Sharing concept outlined in the ITI whitepaper entitled Health Information Exchange: Enabling Document Sharing Using IHE Profiles  May be obtained at <a href="http://www.ihe.net/Technical_Frameworks/#iti">http://www.ihe.net/Technical_Frameworks/#iti</a>
IHE IT Infrastructure (ITI) Technical Framework – Volume 1 (ITI TF-1) Integration Profiles, Supplement -- XDS Metadata Update	This supplement updates the XDS and XDR profiles to add support for the updating and deleting of metadata.  May be obtained at <a href="http://www.ihe.net/Technical_Frameworks/#iti">http://www.ihe.net/Technical_Frameworks/#iti</a>

STANDARD	DESCRIPTION
IHE IT Infrastructure (ITI) Technical Framework – Volume 1 (ITI TF-1) Integration Profiles, Supplement -- XDW Cross Enterprise Document Workflow	This supplement enables participants in a multi-organizational environment to manage and track the tasks related to patient-centric workflows as the systems hosting workflow management applications coordinate their activities for the health professionals and patients they support. May be obtained at <a href="http://www.ihe.net/Technical_Frameworks/#iti">http://www.ihe.net/Technical_Frameworks/#iti</a>
RFC 5545 Internet Calendaring and Scheduling Core Object Specification (iCalendar)	Defines the iCalendar data format for representing and exchanging calendaring and scheduling information such as events to-dos, journal entries, and free/busy information, independent of any particular calendar service or protocol.  May be obtained at <a href="https://datatracker.ietf.org/doc/rfc5545/">https://datatracker.ietf.org/doc/rfc5545/</a>

## 6.1 COPYRIGHT PERMISSIONS

### ***IHE:***

IHE materials used in this document have been extracted from relevant copyrighted materials with permission of Integrating the Healthcare Enterprise (IHE) International. Copies of this standard may be retrieved from the IHE Web Site at [www.ihe.net](http://www.ihe.net).

### ***HL7:***

Certain materials contained in this Interoperability Specification are reproduced from Health Level Seven (HL7) Version 3.0, Health Level Seven (HL7) Version 3.0 Clinical Document Architecture (CDA/CDA R2), and HL7 Implementation Guide: CDA Release 2 – Continuity of Care Document (CCD), Release 1.0, April 01, 2007 with permission of Health Level Seven, Inc. No part of the material may be copied or reproduced in any form outside of the Interoperability Specification documents, including an electronic retrieval system, or made available on the Internet without the prior written permission of Health Level Seven, Inc. Copies of standards included in this Interoperability Specification may be purchased from the Health Level Seven, Inc. Material drawn from these standards is credited where used.

## **7. APPENDIX A: SAMPLE MESSAGES**

EXAMPLES WILL BE PROVIDED AS PART OF THE IS SPECIFICATION VALIDATION PROCESS. UNTIL THEN THIS SECTION WILL REMAIN BLANK.